



# The Housing Authority of The City of Fort Myers

Invitation for Bid

**IFB No. 22-04, Security Site Lighting for  
Horizon Apartments**

April 7, 2022

Housing Authority of the City of Fort Myers, Florida  
4224 Renaissance Preserve Way  
Fort Myers, FL 33916



## TABLE OF CONTENTS

Item	Page No.
Introduction to Bidders	4
Timeline	5
Background	6
Section I - Scope of Services	7
Section II – General Terms & Conditions	8-9
Section III – Special Conditions	10-12
Section IV – Supplemental Conditions	13-19
Section V – Insurance	20
Section VI – Vendor Submittals	21
Bid Form	22-23
Attachment A – Proposers Check List	24
Attachment B – Plans and Specifications	25-35 (10 pages)

### Required Forms

1. Bid Form / Bid prices offered have been reviewed.
2. Vendor Submittals / Section VI
3. 5369 Instructions to Bidders for Contracts
4. 5369-A Representations, Certifications, and Other Statements of Bidders
5. 5370 General Conditions for Construction Contracts - Public Housing Programs
6. Disclosure of Lobbying Activities
7. Non-Collusion Affidavit of Contractor
8. 50070 Drug Free Workplace
9. Public Entity Crime Form
10. 92010 HUD Equal Employment Opportunity Form
11. Section 3 and Minority Business
12. Davis Bacon Current Wage Determinations as outlined on page 7, Item 3,
13. Wage Determination Form WH347 (Certified Payroll)

HACFM Procurement Contact:

[Procurement@hacfm.org](mailto:Procurement@hacfm.org)

Ph: 239-344-3241

Cell: 239-770-5206



## ADVERTISEMENT

The Housing Authority of the City of Fort Myers (HACFM) is seeking sealed bids from licensed and experienced contractors for IFB No. 22-04, Security Lighting for Horizon Apartments.

Bid submittals shall be based on a complete set of construction documents which includes but is not limited to labor, materials, permits, and cost for installation of a complete electrical system for Horizon Apartments.

**On-Site Pre-Bid Meeting:** Horizon Apartments, 5360 Summerlin Rd, Fort Myers, FL 33919, **April 18, 2022 @ 9:00 a.m.**

Specifications and solicitation documents may be examined and downloaded online at: <http://www.hacfm.org/web/page.asp?urh=BusinessOpps>

HACFM will receive electronic submissions of Proposals sent to [Procurement@hacfm.org](mailto:Procurement@hacfm.org) on or before **May 9, 2022 @ 4:00 P.M.**

**Advertise: April 10, 2022, and April 17, 2022**



The Housing Authority of the City of Fort Myers (HACFM), Florida is requesting sealed bids for **IFB No., 22-04, Security Site Lighting for Horizon Apartments.**

HACFM will receive electronic submissions of Proposals sent to [Procurement@hacfm.org](mailto:Procurement@hacfm.org) on or before May 9, 2022 @ 4:00 P.M.

**IMPORTANT:** Please be sure to label the email Subject Line as follows: “IFB No., 22-04, Security Site Lighting for Horizon Apartments.” The email date and time stamp shall serve as the official receipt and late submissions shall not be accepted. HACFM shall not be responsible or liable for any lost or misdirected responses. Submissions are the responsibility of the proposer.

**Questions:** All questions about the meaning or intent of the IFB documents are to be directed to Procurement, e-mail: [Procurement@hacfm.org](mailto:Procurement@hacfm.org). Questions received less than seven (7) days prior to solicitation dues date may not be answered. Only questions answered by formal written addenda will be binding. Oral and other interpretations or clarifications will be without legal effect.

**ADDENDUMS: All ADDENDUMS shall be placed on the HACFM website. Bidders will not be notified when an ADDENDUM is issued.**

**It is the responsibility of the bidder to check the website for any ADDENDUMS.**

<http://www.hacfm.org/web/page.asp?urh=BusinessOpps>

HACFM reserves the right to waive formalities in any bid submittal; to reject any or all bids with or without cause. If applicable, HACFM reserves the right to select one or more vendors to provide the services and to select the bid(s) that, in its judgment, will be in the best interest of the HACFM.



**Timeline:**

***Timeline is provided as a guideline only and is subject to change at the discretion of HACFM.***

Action	Estimated Date of Completion
IFB Issued and made available	April 10, 2022
On-Site Pre-Bid Meeting: Horizon Apartments 5360 Summerlin Rd, Fort Myers, FL 33919	April 18, 2022 @ 9:00 a.m.
Deadline for submitting questions	May 2, 2022
Sealed Bid submission deadline	May 9, 2022 @ 4:00 p.m.
Contract Award	TBD

*There is no obligation on the part of the HACFM to select and award any submitting response or to any firm or individual submitting a response. **No work is guaranteed.***



## **BACKGROUND:**

### ***The Housing Authority of the City of Fort Myers***

The Housing Authority of the City of Fort Myers (the “Authority” or HACFM) is a public housing (PH) authority created pursuant to Chapter 421 of the Florida Statutes of 1969. Being a municipal dependent special district, the Authority has general statutory authority to operate within the City limits of Fort Myers (the “City”), Lee County, Florida. The Authority develops, owns, and manages public and affordable housing. The Authority is responsible for the administration/management of 570 units of low rent Public Housing (PH), 604 LIHTC Tax Credit Units, 210 Section 8 Project Based Units, 200 Mainstream vouchers, 86 Emergency Housing Vouchers and 2014 total other vouchers.

The City of Fort Myers has a diverse population, and the Authority provides affordable housing for the low-income individuals and families who cannot afford housing in the private market. The Authority has partnered with the City, the Lee County Housing Finance Authority (the “County”), other local profit, and not-for-profit groups and citizens of the community desiring to provide more affordable housing options within the City: to rehab units; to redevelop PH; to create new housing (inclusive of new PH units); to support development of community services and resources for the citizens and to seek out new funding sources for the Authority. The Authority and its partners are committed to preserving the community historical roots while building and redeveloping a community that is affordable and viable in the present.

The Southwest Florida Affordable Housing Choice Foundation, Inc., an affiliate nonprofit 501(c)(3) corporation of the HACFM was formed in 2006 to provide, develop and manage affordable housing opportunities on behalf of the HACFM, who currently manage 142 units.



## SECTION I: SCOPE OF WORK

**Questions:** All questions about the meaning or intent of the IFB documents are to be directed to Procurements, e-mail: [Procurement@hacfm.org](mailto:Procurement@hacfm.org).

**Any questions directed the Architect and/or Engineer for this project may not be answered and only questions answered by HACFM in a formal written addenda will be binding. Oral and other interpretations or clarifications will be without legal effect.**

**Plans and Specifications are attached as Exhibit B.**

1. Electrical Plans:
  - a. Sheet E1, General Electrical Notes and Requirements & Light Fixture Schedule
  - b. Sheet E2, Overall Site Electrical Plan
  - c. Sheet E3, Partial Site Electrical Plan
  - d. Sheet E4, Partial Site Electrical Plan
  - e. Sheet E5, Partial Site Electrical Plan
2. Light Fixture Schedule:
  - a. Sheet SL1, Overall Site Lighting Plan
  - b. Sheet SL2, Partial Site Lighting Plan
  - c. Sheet SL3, Partial Site Lighting Plan
  - d. Sheet SL4, Partial Site Lighting Plan
3. Projects in excess of \$2,000 in labor costs shall be in compliance with Davis Bacon Wage Determination(s) No. 2015-4529 Date of last revision 03/15/2022, FL20220120 date of last revision 02/25/2022 and/or FL20220211, date of last revision 02/18/2022. Wage Determinations are update periodically, and it is the contractor's responsibility to keep apprised of rates associated with the work/trade.

Davis Bacon Wage Determination(s) Look-up link below:  
Choose - Public Works or Service Contract  
Drop down: Select State and then County (Florida – Lee County)

<https://sam.gov/content/wage-determinations>



## Section II General Terms and Conditions:

1. Contractor must be licensed and follow all local State and Federal rules and regulations including OSHA regulations.
2. Contractor shall keep work area clean and organized and remove all debris on a daily basis.
3. Contractor shall dispose debris of any kind in HACFM dumpsters.
4. Contractor must keep entrance way clean and safe from hazards.
5. Contractor(s) shall be responsible for the conduct and performance of the contractor's employees. At all times when on HACFM property contractor(s) and employees shall have badges and/or uniforms that visibly identify them as employees of contractor.
6. Contractor(s) personnel shall be neat and conduct all work in a professional manner with minimal disturbance to the property's residents and the public.
7. Contractor(s) shall be responsible for providing the appropriate types and skill levels of personnel, which is considered customary in the industry, required to accomplish the work.
8. Contractor(s) shall commence and end all services on the same day unless otherwise agreed to by HACFM.
9. If at any time the project including but not limited to water, gas, or sewer, to the property must be disconnected or interrupted, contractor must provide advanced notice to the Horizon Property Manager or his/her designee prior to disrupting service so that tenants can be provide a 48-hour notice.
10. Contractor(s) shall maintain industry standard quality of work and guarantee all installations meet and pass city inspections. If work does not pass inspection, contractor shall make all repairs necessary to pass inspection at no additional cost to HACFM.
11. Contractor(s) shall not be relieved from assuming all responsibility for properly estimating the difficulties and the cost of performing the services required.
12. All work shall be performed in accordance with industry standards, according to the material/manufacturer recommendations and to satisfaction of HACFM.





13. Contractor(s) and employees shall be pro-active and keep HACFM apprised of all recommendations, malfunctions, and any corrective action that may need to be taken on a regular basis. No work shall be done without the pre-approval of HACFM.
14. Any required staging areas shall be in accordance with HACFM's direction and Contractor shall maintain any staging area in a neat and presentable condition at all times.
15. Contractor(s) shall immediately notify HACFM Staff of any damages to the facilities as a result of the Contractors operations. Any damages to property by the Contractor shall be repaired to like condition and be paid for by the Contractor.



## Section III: Special Conditions

### 1. Contract Documents:

a. All Specifications, Drawings and copies thereof furnished by HACFM, to the contractor, shall remain HACFM's property and shall not be used on any other Project.

### 2. Owner:

a. The Contractor shall obtain the Owner's written consent prior to changing any project superintendent.

c. All shop drawings, product data, samples and similar submittals shall be reviewed and approved by the Contractor first, who shall then submit them to the Architect/Engineer.

### 3. Contractor:

a. Should the Architect / Engineer or Owner find any person(s) employed on the project to be incompetent, unfit, or otherwise objectionable for his duties and so certifies the facts to the Contractor, Contractor shall immediately cause the employee to be dismissed and said employee shall not be re-employed on this project without written consent of the Architect/Engineer or Owner."

b. The Contractor shall obtain the Owner's written consent prior to changing any project superintendent. Such consent shall be freely given where justice requires.

c. All shop drawings, product data, samples and similar submittals shall be reviewed and approved by the Contractor first and shall then submit them to the Architect/Engineer and/or Owner for approval.

### 4. Administration of Contract:

a. Within ten (10) days after the effective date of the Contract, but before the Contractor starts to work at the site, a Pre-Construction Meeting shall be held and attended by the Contractor, Architect/Engineer, and Owner. This meeting will be held to discuss schedules for completion of the work, procedures for handling shop drawings and other submittals, for processing applications for payment, and to establish a working understanding among the parties as to the work.



**5. Notice To Proceed:**

a. Written Notice to Proceed is contingent upon and will be done subsequent to the Contractor fully satisfying HACFM's stated insurance and Bond submittal requirements. Until the Contractor receives a written Notice to Proceed, the Contractor is advised that HACFM will not be liable for any expenses which the Contractor may incur relative to this Project before the written Notice to Proceed is issued.

b. The Contractor is required before commencing work, to deliver a Payment and Performance Bond issued by a surety authorized to do business in the State of Florida to HACFM Procurement.

c. HACFM will provide to the Contractor a Notice of Commencement of which the Contractor shall file with the Lee County Clerk of Court. A copy of the Certified Notice of Commencement shall be provided to HACFM Procurement.

**5. Changes In Work:**

a. The Contract Documents may be amended to provide for additions, deletions and/or revisions in work or to modify the terms and conditions in one or more of the following ways:

- i. A formal Written Amendment
- ii A Change Order
- iii A Field Directive Change

b. Change Orders must be submitted on AIA Forms and be itemized. Change Orders shall be received and approved prior to any changes on the project. If approved, the Contractor shall provide copies of the Change Order if applicable to all permitting authorities.

d. Where changes in the work result in the request for additional contract time: consideration shall be given for "time" only.

e. Should performance of the Contractor's work be delayed by adverse weather conditions or other conditions which prevent all work during any given day shall be considered lost time.



**7. Payments And Completion:**

a. Final Payment and/or release of retainage shall not be made until the project is inspected and accepted by the Architect/Engineer and Owner and all other authorities required by Lee County and Florida Law.”

b. Retainage: Ten percent (10%) retainage shall be held until final completion and acceptance of the project including but not limited to Contractors Certified Payroll in accordance with the Davis Bacon Wage Determination for time worked.



## **Section IV: Supplemental Instructions**

### **1. DEFINITIONS:**

- a. All definitions set forth in the standard form of general conditions for the construction contract are applicable to these supplemental instruction to bidders.
- b. Bid documents include the invitation to bids, instructions to bidders, the bid form, the general conditions, including any addendum issued prior to the time specified for receipt of bids by HACFM.
- c. Addendums are written or graphic instruments issued prior to execution of the contract which modify or interpret the bid documents, including drawings and specifications, by additions, deletions, clarifications, or corrections. Addendum will become part of the Contract Documents when the construction contract is executed.
- d. Responsible Bidder: A contractor, business entity who is full capable to meet all of the requirements of the IFB and subsequent contract. Must possess the full capability, including financial and technical, to perform as contractually required. Must be able to fully document the ability to provide good faith Performance.
- e. Responsive Bidder: A contractor who has submitted a bid that fully conforms in all material respects to the IFB and all its requirements, including all forms and substance. Each bidder by making his bid represents that he has read and understands the documents.

### **4. EXAMINATION OF BID DOCUMENTS**

- a. Each bidder by making a bid represents that the site was visited and familiarized himself with the local conditions under which the work is to be performed, particularly the Davis Bacon Wage Determination for this project.
- b. Bidders taking exception to any part or section of the bid must indicate on a separate sheet entitled "EXCEPTIONS TO BID SPECIFICATIONS." Failure to indicate any exceptions shall be interpreted as the Bidders intent to fully comply with the specifications written.
- c. Unless otherwise provided in any supplement to these INSTRUCTIONS, no bidder shall modify, withdraw, or cancel his bid or any part thereof for ninety (90) days after the time designated for the receipt of bids in this document.



## 5. PREPARATION AND SUBMISSION OF BIDS

- a. Each bidder shall use the BID FORM on indicating prices and project duration days thereon in proper spaces. The prices and days shall be for the entire work and for any alternates specified. Any erasures or other corrections in the bid must be explained or noted over signature of bidders. Bids containing any conditions, omissions, unexplained erasures, alterations, items not called for, or irregularities of any kind, may be rejected by HACFM at their sole discretion.
- b. In no case shall notations of any kind on the envelope alter the contents of the bid documents.
- c. Bids shall be reviewed by HACFM, the Architect/Engineer for the most responsive responsible bid. HACFM shall consider past performance.

## 6. QUALIFICATIONS OF BIDDERS:

- a. Bidders on any construction project must be qualified and directly responsible for a minimum of 50% or more of the bid amount for said work.
- b. Provide all permits, certifications, and licensing required to perform the work requested. Contractor must comply with and provide proof that all permitting, and licensing requirements have been met as set forth by state, local, federal or any other governing agency.

## 7. DISQUALIFICATION OF BIDDERS:

- a. More than one bid from an individual, firm, partnership, corporation, or association under the same or different names will not be considered. Any or all bids will be rejected if there is reason to believe that collusion exists among the bidders and no participants in such collusion will be considered in future bids for the same work. Bids in which the prices are obviously unbalanced will be rejected.
- b. Owner reserves the right to reject any bids where an investigation of the available evidence or information does not satisfy the Owner that the bidder is qualified to carry out properly the terms of the contract documents.

## 8. BID GUARANTEE:

- a. Each bid must be accompanied by a BID BOND in an amount not less than five percent (5%) of the total amount of the bid and any alternates as a guarantee that the bidder will not withdraw his bid for a period of ninety (90) days after the scheduled time for



the receipt of bids. If recommended for award, the Contractor will enter into a contract with HACFM. The Contract shall require evidence of all referenced insurance contained in this bid documents. Insurance includes Workmen's Compensation, and Public Liability Insurance, approval of subcontractors by the Owner, and delivery of a PERFORMANCE and PAYMENT BOND satisfactorily to the Owner within ten (10) days after the meeting at which the contract is awarded.

- b. The failure of a successful bidder to execute such contract and to supply the required bonds within ten (10) days after award of the contract, or within such extended period as Owner may grant, shall constitute a default and Owner may either award the contact to the next responsible bidder or re-advertise for bids. The defaulting bidder shall be responsible for the difference between the amount of the contract subsequently awarded and the bid of the defaulting bidder.
- c. Bid Guarantee will be returned to all except the three low bidders after opening of the bids only upon the request of the contractor. The remaining guarantees will be returned to the three lowest bidders after the Owner and the accepted bidder have executed the contract and the PAYMENT and PERFORMANCE BONDS have been approved by the Owner and only at the request of the Contractor.
- d. All bid guarantees shall meet surety requirements as set forth.

## 9. OPENING OF BIDS:

- a. Bids shall not be made public until such time as the bids have been evaluated, awarded and the contract has been executed.

## 10. BID MODIFICATION:

**Mistakes Before Bid Opening.** Unless otherwise prohibited by State or local law, bidders shall be permitted to withdraw or modify their bids by written or facsimile notice prior to bid opening (see form HUD-5369, Item 5, and form HUD-5369-B, Item 6). In no case shall notations of any kind on the bid envelope alter the contents of the bid documents.

## 11. WITHDRAWAL OF BIDS:

**Withdrawal of Bids.** Withdrawal of a bid is permissible if there is an obvious error in the bid such as a math error, but the mistake must be readily apparent from the bid itself. A bidder may be permitted to withdraw a low bid if a mistake is clearly evident on the face of the bid document, but the intended correct bid is not similarly evident. A bidder may also be permitted to withdraw a low bid if the bidder submits written evidence that clearly



and convincingly demonstrates that a mistake was made. HACFM shall require written supporting evidence before allowing withdrawal by the bidder.

**12. REJECTION OF BIDS:**

**Rejection of Bids** Rejection of any bid during the evaluation process shall be fully documented, including all reasons for the rejection. Minor informalities in the bid may be waived, as described above. Any bid may be rejected if the Contracting Officer determines that the price is unreasonable. Determining a bid price to be unreasonable includes not only the total price of the bid, but the prices for individual items as well. Any bid may be rejected if the prices for any of the items are materially unbalanced (such as bidding a high price for the first items to be provided and then low prices for subsequent items). A bid is materially unbalanced if and when there is a reasonable doubt that the bid would result in the lowest overall cost to HACFM, even if it is the lowest bid, or if the bid is so grossly unbalanced that accepting it would amount to an advance payment.

**13. AWARD OF CONTRACT:**

- a. Owner will consider the project materials, schedule, approach to the intent of the scope of work and associated costs in determining in its opinion what is in the best value to HACFM when awarding the project. Award of the contract, if awarded, will be within ninety (90) calendar days after opening the bids.
- b. Alternate bids will not be considered unless specified in the bidding documents and bid proposal form or by written Addendum.

**14. LIST OF SUBCONTRACTORS: (If Applicable)**

- a. Each bidder shall submit to Owner a list of subcontractors and major material suppliers to be used if awarded the contract. The selected bidder shall within seven (7) days submit all information required to establish to the satisfaction of HACFM, the reliability and responsibility of the proposed subcontractors to furnish and perform the work described in the sections of the specifications pertaining to such proposed subcontractor's respective trades. Prior to the award of the contract, HACFM will notify the bidder in writing if, after investigation, has reasonable and substantial objection to any person or company on the list. If HACFM has a reasonable and substantial objection to any person or company on the list and refuses in writing to accept such person or company, the bidder, may at his option, withdraw their bid without forfeiture to bid security. There shall not be any changes in cost proposed by the bidder. Subcontractors and other persons and companies proposed by the bidder and accepted by HACFM must be used on the work for which they were proposed and accepted and shall not be changed except with written approval of HACFM.





**15. PERFORMANCE AND PAYMENT BOND:**

- e. Each bid must be accompanied by a BID BOND in an amount not less than five percent (5%) of the total amount of the bid and any alternates as a guarantee that the bidder will not withdraw his bid for a period of ninety (90) days after the scheduled time for the receipt of bids. If recommended for award, the Contractor will enter into a contract with HACFM. The Contract shall require evidence of all referenced insurance contained in this bid documents. Insurance includes Workmen's Compensation, and Public Liability Insurance, approval of subcontractors by the Owner, and delivery of a PERFORMANCE and PAYMENT BOND satisfactorily to the Owner within ten (10) days after the meeting at which the contract is awarded.
- f. The failure of a successful bidder to execute such contract and to supply the required bonds within ten (10) days after award of the contract, or within such extended period as Owner may grant, shall constitute a default and Owner may either award the contract to the next responsible bidder or re-advertise for bids. The defaulting bidder shall be responsible for the difference between the amount of the contract subsequently awarded and the bid of the defaulting bidder.
- g. Bid Guarantee will be returned to all except the three low bidders after opening of the bids only upon the request of the contractor. The remaining guarantees will be returned to the three lowest bidders after the Owner and the accepted bidder have executed the contract and the PAYMENT and PERFORMANCE BONDS have been approved by the Owner and only at the request of the Contractor.
- h. All bid guarantees shall meet surety requirements as set forth.

**16. TAXES:**

- a. HACFM is exempt from the payment of any sales tax to its vendors.

The Housing Authority is also exempt from most Federal excise taxes. By submittal of a properly executed response to a bid from the Housing Authority, the bidder is acknowledging that he is aware of his responsibilities for Florida excise taxes.

- b. Tangible personal property purchased by Contractors in the performance of realty construction for the Housing Authority is taxable, though the Housing Authority is exempt on its own purchases.



## 17. AGGRIEVANCES OR PROTEST:

a. Any contractor/vendor/firm that has submitted a formal bid/quote/proposal to the Housing Authority of the City of Fort Myers (HACFM) and who is adversely affected by an intended decision with respect to the award of the formal bid/quote/proposal, shall file with the Procurement Officer a written notice of intent to file a protest not later than seventy-two (72) hours (excluding Saturdays, Sundays, and Legal Holidays) after receipt of written notice from HACFM of the Intent To Award.

b. For the purpose of computation, the initial notice of intent to file a protest shall be received by the no later than four o'clock (4:00) P.M. on the third working day following the day of receipt of notice of the intended decision or the date of posting of bid tabulation.

c. Any contractor/vendor/firm that has submitted a bid to the HACFM who is affected adversely by the intended decision with respect to bid award, shall file a formal, written protest within five (5) calendar days after the date of filing of the initial notice of intent to file a protest. Upon filing of the Formal Written Protest, the contractor/vendor/firm shall post a bond, payable to the HACFM in an amount equal to five percent (5%) of the total bid/quote/proposal or Ten Thousand Dollars (\$10,000.00) whichever is less. Said bond shall be designated and held for the payment of any costs that may be levied against the protesting contractor/vendor/firm by HACFM, as the result of a frivolous Protest. Said surety shall be in the form of a cashier's check on a national or state bank, money order, or a protest bond executed by the contractor/vendor/firm and a qualified Surety authorized to do business in the State of Florida and acceptable to HACFM.

d. Failure to submit a cashier's check on a national or state bank, money order or bond simultaneously with the Formal Written Protest shall invalidate the protest, at which time HACFM may continue its procurement process as if the original "Notice of Intent to File a Protest" had never been filed.

### e. Decisions

HACFM shall issue a written decision to any properly filed protest within 15 business days of receipt.

### f. Form and Manner of Filing Protests and Decision Appeals

Appeals to protest decisions must be in writing, signed, and explain the basis of the protest, or the appeal will not be considered. All appeals should be served in person, or by certified to the Procurement Officer.



### **g. Reservation of Rights**

A filing, review, or decision of a protest pursuant to this procedure shall not enjoin or prevent HACFM from the exercise of any of its rights or remedies, nor act as a waiver of such rights and remedies. This reservation of rights includes but is not limited to HACFM's exercise of rights in contract, law and equity to give notice to a contractor to proceed with work, enter into or cancel a contract, add, delete, or modify contract specifications, withdraw or reissue specifications, or charge, fine or assess liquidated or contract damages, even in the event that such an action may be the subject of a procurement protest.

### **h. Exhaustion of Remedies**

A person or business entity who has filed a timely notice of procurement protest, received a decision, filed a timely notice of appeal, and received a decision regarding said appeal, shall be deemed to have exhausted administrative remedies with HACFM.

## **18. ADDENDUM:**

The Housing Authority reserves the right to formally issue an addendum for clarify and/or changes to the requirements of the bid specifications where it deems necessary. Any such addendum shall be in writing and shall be posted to the HACFM website. It shall be the bidder's responsibility to monitor the HACFM website for addendums. Addendums will not be distributed to bidders by HACFM. No oral clarifications or amendments shall be considered binding.

Each bidder shall examine the documents carefully and not later than seven (7) calendar days prior to the date for receipt of bids shall make written request to HACFM for interpretation or correction of any ambiguity, inconsistency, or error therein which may be discovered. Any interpretation or correction will be issued as an ADDENDUM. Only a written interpretation or correction by ADDENDUM shall be binding. No bidders shall rely upon any interpretation or correction given by any other method. ADDENDUMS shall be placed on the HACFM website. Bidders will not be notified when an ADDENDUM is issued. It is the responsibility of the bidder to check the website for any ADDENDUMS.



## SECTION V: INSURANCE

**INSURANCE:** The vendor shall secure and maintain during the contract period the following coverage's:

**Workers' Compensation:** Insurance covering all employees meeting statutory limits in compliance with the applicable state and federal laws.

**Commercial General Liability:** Coverage shall have minimum limits of \$1,000,000 per occurrence, combined single limit for bodily injury liability and property damage liability. This shall include premises and operations; broad form property damage; XCU coverage; independent contractors; products and completed operations and contractual liability.

**Business Auto Liability:** Coverage shall have minimum limits of \$1,000,000 per occurrence, combined single limit for bodily injury liability and property damage liability. This shall include: owned vehicles, hired and non-owned vehicles, if applicable.

**Special Provisions:** HACFM is to be specifically included as an **additional insured** on both the comprehensive general liability and the business auto liability policies.

The certificate holder should read as follows: The Housing Authority of the City of Fort Myers, 4224 Renaissance Preserve Way, Fort Myers, Florida 33916

No HACFM Division or individual name should appear on the certificate. No other format will be acceptable. The certificate must state the project number and name.

Current valid insurance policies meeting the requirements herein identified shall be in effect and maintained during the duration of the named project. Renewal certificates shall be sent to HACFM 10- days prior to any expiration date.

**INDEMNIFICATION:** The vendor shall hold harmless and defend The Housing Authority of the City of Fort Myers and its agents and employees from all suits and actions, including attorney's fees and all costs of litigation and judgments of any name and description arising out of or incidental to the performance of this contractor work performed there under.

This provision shall also pertain to any claims brought against the Housing Authority of the City of Fort Myers by any employee of the named contractor, any subcontractor, or anyone directly or indirectly employed by any of them.

The vendor's obligation under this provision shall not be limited in any way by the agreed upon contract price as shown in this contract or the contractor's limit of, or lack of, sufficient insurance Protection.



## **SECTION VI: VENDOR SUBMITTAL SECTION**

1. References – minimum of three (3) references. Include the companies name, address, contact person, phone number and email address. Prefer a minimum of one (1) governmental reference, however, this is not a mandate.
2. List of any subcontractors to be used on this project. Name of company and a description of work they perform for the contractor(s).
3. Workmanship Warranties.
4. Forms and documents required under Attachment A.



## Bid Form

### IFB No. 22-04, Security Site Lighting for Horizon Apartments

Description of the Work	Lump Sum
<b>Base Bid:</b> Lighting of the entire property (Parking Lot, Perimeter and Buildings)	\$
<b>Deduct Alternates:</b>	
Deduct: Parking Lot Lighting	\$
Deduct: Perimeter Lighting	\$
Deduct: Building Lighting	\$

Project shall be completed within \_\_\_\_\_ Calendar days from the Notice to Proceed.

**IMPORTANT: Please be sure to label the email Subject Line as follows:**

**“IFB No., 22-04, Security Site Lighting for Horizon Apartments”**

The undersigned, herein referred to as the Proposer, has familiarized themselves with the IFB in its entirety and the local conditions under which the work is to be performed and is satisfied with the conditions of delivery, handling and storage of equipment and all other matters which may be incidental to the work, before submitting a proposal.

The undersigned agrees, if this proposal is accepted, to furnish any and all items/services upon which prices are offered, at the price(s) and upon the terms and conditions contained in the Specifications. The period for acceptance of this Proposal will be one hundred eighty (180) calendar days.

By submitting a proposal in response to this solicitation, the bidder/proposer certifies that at the time of submission, he/she is not on the Federal Government’s or the State of Florida’s list of suspended, ineligible, or debarred contractors.

In the event of placement on the list between the time of bid/proposal submission and time of award, the bidder/proposer will notify the HACFM. Failure to do so may result in terminating this contract for default.

The undersigned affirms that they have read and do understand the specifications and any attachments contained in this IFB package.



By signing this document I, an authorized representative of the Proposer, certify that my company has not, either directly or indirectly, entered into any agreement or participated in any collusion or otherwise taken any action in restraint of free competition; that no attempt has been made to induce any other person or firm to submit or not to submit a Proposal; that the Proposal we have submitted for this IFB has been independently arrived at without collusion with any other Proposer, competitor or potential competitor; that our Proposal has not been knowingly disclosed prior to the opening of Proposals to any other Proposer or competitor; that the above statement is accurate under penalty of perjury.

Failure to sign and return this form will result in the rejection of the entire proposal.

ALL SUBMISSIONS MUST BE EXECUTED BY AN AUTHORIZED AUTHORITY OF THE BIDDER/PROPOSER

---

Company Name

---

Print Name and Title of Authorized Representative

---

Signature of Authorized Representative

Date



## **Attachment A**

### **CHECK LIST FOR PROPOSAL SUBMISSION**

Please read carefully, sign in the spaces indicated and return with your bid/proposal.  
Proposer should check off each of the following items as the necessary action is completed.

#### **Required Forms**

- a. Bid Form / Bid prices offered have been reviewed.
- b. Vendor Submittals / Section VI
- c. 5369 Instructions to Bidders for Contracts
- d. 5369-A Representations, Certifications, and Other Statements of Bidders
- e. 5370 General Conditions for Construction Contracts - Public Housing Programs
- f. Disclosure of Lobbying Activities
- g. Non-Collusion Affidavit of Contractor
- h. 50070 Drug Free Workplace
- i. Public Entity Crime Form
- j. 92010 HUD Equal Employment Opportunity Form
- l. Section 3 and Minority Business
- m. Davis Bacon Current Wage Determinations as outlined on page 7, Item 3
- n. Wage Determination Form WH347 (Certified Payroll)

I acknowledge receipt of the following addenda, and the cost, if any, of such revisions has been included in the price of the proposal.

Addendum # _____	Date: _____	Addendum # _____	Date: _____
Addendum # _____	Date: _____	Addendum # _____	Date: _____





## Attachment B

### Plans and Specifications:

1. **Electrical Plans:**
  - a. **Sheet E1, General Electrical Notes and Requirements & Light Fixture Schedule**
  - b. **Sheet E2, Overall Site Electrical Plan**
  - c. **Sheet E3, Partial Site Electrical Plan**
  - d. **Sheet E4, Partial Site Electrical Plan**
  - e. **Sheet E5, Partial Site Electrical Plan**
2. **Light Fixture Schedule:**
  - a. **Sheet SL1, Overall Site Lighting Plan**
  - b. **Sheet SL2, Partial Site Lighting Plan**
  - c. **Sheet SL3, Partial Site Lighting Plan**
  - d. **Sheet SL4, Partial Site Lighting Plan**

# A SITE LIGHTING PROJECT AT: THE HORIZONS APARTMENTS

FOR THE HOUSING AUTHORITY OF THE  
CITY OF FT MYERS

5300 - 5360 SUMMERLIN ROAD

FORT MYERS, LEE COUNTY FLORIDA 33919

STRAP#: 11-45-24-P1-00060.0010 / FOLIO#: 10196080

SET NO:

REVISIONS:  
XXXX/2021 (XXX)  
(DEF.)

**MSA MOORE & SPENCE ARCHITECTS, P.A.**  
12613 NEW BRITTANY BLVD.  
FORT MYERS, FLORIDA 33907  
(239) 278-3520 FAX (239) 278-3519  
AR #0016335 / AR #0016335

COVER SHEET

**THE HORIZONS APARTMENTS**  
FOR THE HOUSING AUTHORITY OF  
THE CITY OF FORT MYERS,  
FORT MYERS, LEE COUNTY, FLORIDA  
COVER SHEET

JOB No:  
**21048**  
03/14/2022

SHEET No:  
**CS1**

Drawing Log: XX/XX/XX (XXX) XX/XX/XX (XXX) XX/XX/XX (XXX) XX/XX/XX (XXX) 12/2/2021 10:33 AM 21048-01-CS1.dwg  
Vic DePue, Moore and Spence Architects

COPYRIGHT 2021 / MOORE & SPENCE ARCHITECTS, P.A. / ALL RIGHTS RESERVED / UNAUTHORIZED REPRODUCTION OR MODIFICATION OF THESE PLANS OR DRAWINGS ARE STRICTLY PROHIBITED.

## GENERAL CONSULTANTS:

**OWNER:** THE HOUSING AUTHORITY OF THE CITY OF FORT MYERS  
4224 RENAISSANCE PRESERVE WAY  
FORT MYERS, FLORIDA 33916

**ARCHITECTURAL:** MOORE & SPENCE ARCHITECTS, P.A.  
12613 NEW BRITTANY BOULEVARD  
FORT MYERS, FLORIDA 33907  
(239) 278-3520 FAX (239) 278-3519

**PLUMBING / MECHANICAL / ELECTRICAL ENGINEER:** BURGESS ENGINEERING, INC.  
12995 S. CLEVELAND AVE, SUITE 229  
FORT MYERS, FLORIDA 33907  
(239) 274-0020 FAX (239) 274-0021

## LOCATION MAP:

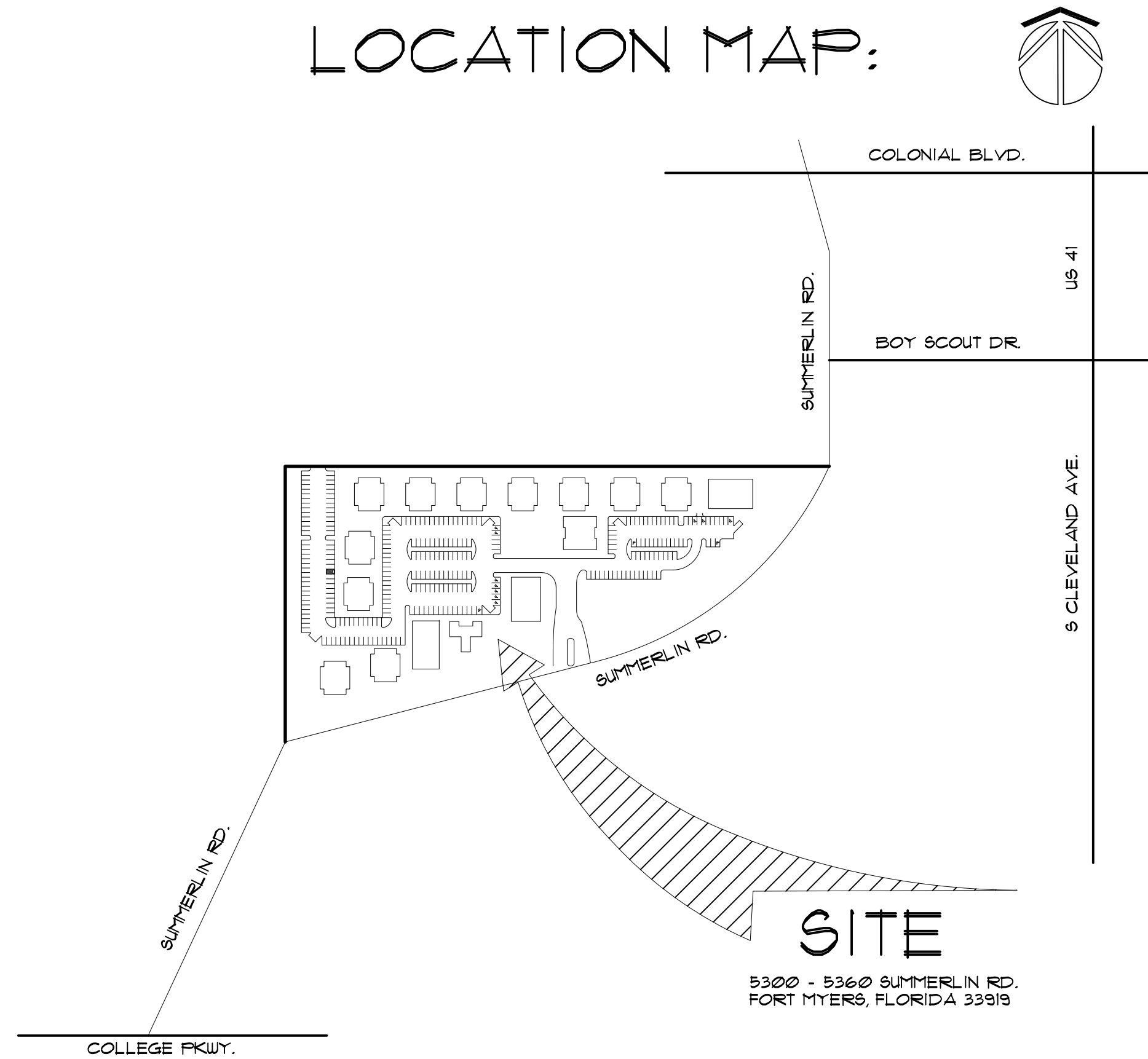

## DRAWING INDEX:

- CS1 COVER SHEET / LOCATION MAP / GENERAL CONSULTANTS / DRAWING INDEX
- ELECTRICAL:**
- E1 LIGHTING FIXTURE SCHEDULE / PANEL SCHEDULE / NOTES AND REQUIREMENTS / SYMBOL LEGEND / SPECIFIC NOTES / ABBREVIATIONS / POWER RISER DIAGRAM
  - E2 OVERALL SITE ELECTRICAL PLAN
  - E3 PARTIAL SITE ELECTRICAL PLAN
  - E4 PARTIAL SITE ELECTRICAL PLAN
  - E5 PARTIAL SITE ELECTRICAL PLAN
- SITE LIGHTING:**
- SL1 OVERALL SITE LIGHTING PLAN
  - SL2 PARTIAL SITE LIGHTING PLAN
  - SL3 PARTIAL SITE LIGHTING PLAN
  - SL4 PARTIAL SITE LIGHTING PLAN

## RESPONSIBILITY AND LIABILITY CLAUSE:

THE DESIGN PROFESSIONAL WAIVES ANY AND ALL RESPONSIBILITY AND LIABILITY FOR PROBLEMS WHICH ARISE FROM FAILURE TO FOLLOW THESE PLANS, SPECIFICATIONS AND THE DESIGN INTENT THEY CONVEY, OR FOR PROBLEMS WHICH ARISE FROM OTHERS FAILURE TO OBTAIN AND / OR FOLLOW THE DESIGN PROFESSIONAL'S GUIDANCE WITH RESPECT TO ANY ERRORS, OMISSIONS, INCONSISTENCIES, AMBIGUITIES OR CONFLICTS WHICH ARE ALLEGED.

## SPECIFICATIONS

SPECIFICATIONS FOR MATERIALS ARE DESCRIBED ON THE DRAWINGS, UNLESS OTHERWISE SPECIFIED THE INSTALLATION OF ALL MATERIALS SHALL BE PER THE MANUFACTURERS RECOMMENDATIONS. NO SPECIFICATION BOOK HAS BEEN PREPARED FOR THIS PROJECT.

## CONTRACT DRAWING APPROVAL

OWNER \_\_\_\_\_  
CONTRACTOR \_\_\_\_\_



**GENERAL ELECTRICAL NOTES AND REQUIREMENTS**

- GENERAL INSTALLATION REQUIREMENTS:**
    - THE ELECTRICAL CONTRACTOR SHALL COMPLY WITH THE 2020 FLORIDA BUILDING CODE, THE FLORIDA FIRE PREVENTION CODE (SEVENTH EDITION) WITH CHAPTER 69A-60 APPLICABLE N.F.P.A. CODES WHICH INCLUDES THE 2017 N.E.C. (N.F.P.A. - 70) AND THE 2018 LIFE SAFETY CODE (N.F.P.A. - 101) FLORIDA EDITION.  
THE INSTALLATION OF THE SYSTEMS SHALL BE IN ACCORD WITH THE MATERIALS AND METHODS INDICATED IN THE PLANS AND SPECIFICATIONS. ANY DESIRED DEVIATIONS SHALL BE SUBMITTED (IN WRITING) TO AND APPROVED BY THE ENGINEER. IF NOT INCLUDED IN THE SUBMITTALS AND NOT SPECIFICALLY REQUESTED, MATERIALS AND METHODS SHALL BE PROVIDED PER PLANS AND SPECIFICATIONS.
    - THE CODES REPRESENT THE MINIMUM INSTALLATION CRITERIA FOR THE PROJECT. IT IS THE RESPONSIBILITY OF THE INSTALLING CONTRACTOR TO ADHERE TO THE DESIGN DOCUMENTS SO LONG AS THEY DO NOT INDICATE INSTALLATIONS THAT WILL PRESENT CODE VIOLATIONS. NO ADDITIONAL CHARGES WILL BE APPROVED OR ACCEPTED TO CHANGE THE INSTALLATION IN ORDER TO COMPLY WITH CODE OR TO RETROFIT ANY WORK THAT WAS INSTALLED IN VIOLATION OF A CODE.
    - WORK SHALL INCLUDE ALL LABOR, MATERIALS, PERMITS AND COSTS FOR INSTALLATION OF A COMPLETE ELECTRICAL SYSTEM.  
THE ELECTRICAL CONTRACTOR IS RESPONSIBLE FOR INSTALLING ALL CONDUITS, AND BACK BOXES AS MAY BE REQUIRED FOR INSTALLATION OF THE LOW VOLTAGE SYSTEMS, AND FOR ALL CONNECTIONS TO THE 120 OR 277 VOLT POWER SOURCES.
    - IT IS NOT THE PURPOSE OF THESE PLANS TO SHOW ALL DETAILS OF CONSTRUCTION, ONLY THE INTENT. ELECTRICAL CONTRACTOR IS RESPONSIBLE FOR THE PURCHASE AND INSTALLATION OF ALL ITEMS SUCH AS HARDWARE, J-BOXES, CONDUITS AND FITTINGS, ETC., AS NECESSARY FOR A COMPLETE ELECTRICAL SYSTEM IN WORKING ORDER.
    - CONTRACTOR IS RESPONSIBLE FOR PROVIDING COMPLETE BIDS BASED UPON THE ENTIRE SET OF CONSTRUCTION DOCUMENTS. THIS EXTENDS TO ALL DEVICES INDICATED ON PLANS AND ALL EQUIPMENT REQUIRED TO SUPPORT THOSE DEVICES. IF FOR ANY REASON, THE INTENT OF THE ENGINEER, ARCHITECT OR CLIENT IS UNCLEAR THEN THE CONTRACTOR IS TO GET CLARIFICATION PRIOR TO PROVIDING A BID. IF THE CONTRACTOR FAILS TO DO SO, THE CONTRACTOR SHALL BE REQUIRED TO ASSUME ANY ADDITIONAL COSTS INVOLVED IN REALIZING THE INTENT OF THE ENGINEER, ARCHITECT, OR CLIENT.
    - ALL EQUIPMENT, FIXTURES, ETC., SHALL BE STARTED, TESTED, ADJUSTED AND PLACED IN SATISFACTORY OPERATING CONDITION BY THIS CONTRACTOR WHO SHALL GUARANTEE ALL WORKMANSHIP, MATERIALS AND EQUIPMENT TO BE FREE OF DEFECTS FOR A PERIOD OF (1) ONE YEAR FROM DATE OF OWNER ACCEPTANCE, AND SHALL REPAIR SUCH DEFECTS WITHOUT COST TO THE OWNER. ALL EQUIPMENT SHALL BE COVERED FOR THE DURATION OF THE MANUFACTURER'S GUARANTEE OR WARRANTY, AND THIS CONTRACTOR SHALL FURNISH THE OWNER WITH ALL MANUFACTURER'S GUARANTEES AND WARRANTIES.
    - ELECTRICAL CONTRACTOR SHALL BE RESPONSIBLE FOR COORDINATING WITH OTHER PARTIES FOR INSTALLATION OF ALL DEVICES. THIS SHALL INCLUDE (BUT NOT LIMITED TO) THE FOLLOWING:
      - LIGHT FIXTURES ON EXTERIOR OF BUILDING WITH WALL FINISHES/CONSTRUCTION, ETC.
      - LIGHT FIXTURES ON SITE WITH EXISTING/NEW UTILITIES, BUILDINGS/STRUCTURES, PLANTINGS, ETC.
    - IT IS THE CONTRACTOR'S RESPONSIBILITY TO IMMEDIATELY (WITHIN (2) WORKING DAYS OF DISCOVERY) NOTIFY IN WRITING (VIA FAX, EMAIL) OR PHONE CALL AND ASSOCIATED HARD COPY LETTER WITH COPIES TO ALL PARTIES INVOLVED. THE GENERAL AND ELECTRICAL CONTRACTORS SHALL COORDINATE WITH THE APPROPRIATE UTILITY COMPANY WITH REGARDS TO THE ELECTRICAL SERVICE TO THE PROJECT. THIS SHALL OCCUR IMMEDIATELY UPON PROJECT STARTUP PRIOR TO ANY ORDERING MATERIALS OR CONSTRUCTION OF PROJECT. ARCHITECT AND ENGINEER SHALL BE NOTIFIED IN WRITING AS TO THE DATE OF COORDINATION AND THE RESULTS OF THE COORDINATION. ANY ISSUES SHALL BE REVIEWED BY THE ARCHITECT AND ENGINEER AND REVISIONS (IF REQUIRED) SHALL BE MADE PRIOR TO ANY INSTALLATIONS. THE CONTRACTOR/S ARE TO VERIFY ACTUAL AVAILABLE FAULT CURRENT PRIOR TO ANY INSTALLATION. COORDINATE SERVICE EQUIPMENT FAULT CURRENT RATINGS ACCORDINGLY. PROVIDE COST DIFFERENTIAL IN WRITING TO OWNER / ARCHITECT / ENGINEER FOR COST INCREASE OR CREDIT ACCORDINGLY.
    - THE ELECTRICAL, HVAC, PLUMBING, FIRE PROTECTION & GENERAL CONTRACTORS SHALL STRICTLY ADHERE TO THE FOLLOWING ITEMS WHEN DEALING WITH ELECTRICAL CLEARANCES:
      - A CLEARANCE OF 36" MINIMUM SHALL BE MAINTAINED IN FRONT OF ELECTRICAL EQUIPMENT FOR A WIDTH OF 30" OR THE ENTIRE WIDTH OF THE EQUIPMENT (WHICHEVER IS LARGER), AND FROM FLOOR TO SLAB EQUIPMENT OVER 1200 AMPS OR 6 FEET OR GREATER IN WIDTH WITH OVERCURRENT DEVICES REQUIRES A 72" CLEARANCE.
    - DO NOT SCALE THE ELECTRICAL DRAWINGS, REFER TO THE ACTUAL SITE CONDITIONS FOR EQUIPMENT LOCATIONS, WALLS, BUILDINGS, DOOR SWINGS, ETC.
    - NOTICE TO CONTRACTOR:** REVISIONS TO THESE DRAWINGS AND CERTIFICATION THERETO, WHICH MAY BE REQUIRED BY THE APPLICABLE INSPECTION AUTHORITY, BECAUSE OF CONTRACTOR OR "OTHERS" OPTED REVISIONS SHALL BE COMPENSATED TO THE ENGINEER/S BY THE REQUESTING CONTRACTOR. PAYMENT WILL BE REQUIRED AT TIME OF CERTIFICATION DELIVERY.
  - WITHIN 30 DAYS OF PROJECT COMPLETION, RECORD DRAWINGS (AS BUILT) OF THE PROJECT BE PROVIDED BY THE CONTRACTOR/S AND SUBMITTED TO THE OWNER. THESE SHALL INCLUDE (MINIMALLY) A SINGLE LINE POWER RISER, PANEL SCHEDULES AND FLOOR PLANS. IN ADDITION OWNER COPIES OF OPERATIONS MANUALS FOR ALL EQUIPMENT REQUIRING SERVICE WITH NAMES AND ADDRESS, AND, CONTACT FOR QUALIFIED SERVICE AGENCY/S.**  
IT IS HERE NOTED THAT IF THERE ARE NO CONSTRUCTION OBSERVATION ("CO") TRIPS PERFORMED BY THE ENGINEER/S OF RECORD THERE WILL BE NO CERTIFIED PLANS ("AS BUILT") PROVIDED BY THE ENGINEER/S OF RECORD.
- SUBMITTALS**
  - SHOP DRAWINGS SHALL BE PROVIDED FOR ALL ELECTRICAL EQUIPMENT THAT IS TO BE USED ON THIS PROJECT WHETHER OR NOT THE EQUIPMENT IS SPECIFICALLY SPECIFIED IN THESE DOCUMENTS. THIS INCLUDES (BUT IS NOT LIMITED TO) DISTRIBUTION EQUIPMENT, LIGHT FIXTURES, WIRING DEVICES, METERING, CONDUITORS, CONDUITS, FITTINGS, BOXES, GROUNDING METHODS, ETC., SHOP DRAWINGS SHALL BE REQUIRED PRIOR TO ORDERING OR ANY INSTALLATION OF EQUIPMENT. ANY EQUIPMENT NOT INCLUDED IN THE SHOP DRAWING SUBMITTALS, SHALL BE PROVIDED PER THE PLANS AND SPECIFICATIONS.
  - SUBMITTALS ARE TO BE TOTAL & COMPLETE. INCOMPLETE OR PIECEMEAL SHOP DRAWINGS WILL NOT BE REVIEWED. ALL EQUIPMENT (INCLUDING ANY/ALL OPTIONS) SHALL BE CLEARLY SELECTED/INDICATED ON THE CUTSHEETS INCLUDED IN THE SUBMITTALS. ELECTRONIC SUBMITTALS SUBMITTED ARE ACCEPTABLE, HOWEVER ALL COSTS INCURRED WITH PRINTING SHOP DRAWINGS RECEIVED ELECTRONICALLY SHALL BE REIMBURSED.
  - SHOP DRAWINGS SUBMITTED BY WAY OF AN ELECTRONIC PROJECT MANAGEMENT SYSTEM ARE NOT ACCEPTABLE.
- WIRING & WIRING METHODS**
  - ALL CONDUCTORS SHOWN ARE TO BE COPPER WITH THHN/THWN, 75°C INSULATION, UNLESS NOTED OTHERWISE.
  - ALL WIRING DEVICE, EQUIPMENT TERMINALS, SPLICING SYSTEMS, ETC. SHALL BE RATED FOR 75°C CONDUCTORS.
  - MINIMUM WIRE SIZE TO BE #12 Cu, MINIMUM CONDUIT SIZE IS TO BE 1/2". 20 AMP, 120 VOLT CIRCUITS SHALL HAVE CONDUCTORS SIZED PER LENGTH OF RUN (UNO); 55' OR LESS = #12 Cu; 55' - 95' = #10 Cu; 95' - 145' = #8 Cu. THESE SIZES PERTAIN TO THE HOT, NEUTRAL, AND GROUND CONDUCTORS.
  - AS DESIGNED, THE SYSTEM VOLTAGE DROPS ARE LESS THAN 2% FOR FEEDERS AND 3% FOR THE BRANCH CIRCUITS.
  - WIRING TO BE:
    - RS CONDUIT AND CONDUCTORS ABOVE GROUND
    - PVC CONDUIT AND CONDUCTORS UNDERGROUND AND IN SLAB
    - ENT CONDUITS ARE NOT ALLOWED UNDER ANY CIRCUMSTANCE.
    - UNO = NO ALUMINUM CONDUITS OR CABLES ARE ALLOWED.
  - CONTRACTOR SHALL RUN FULL SIZED NEUTRALS FOR ALL CIRCUITS THAT REQUIRE NEUTRALS.
  - CABLING SHALL BE IDENTIFIED USING SELF-ADHESIVE LABELING. MATERIAL SHALL BE PERMANENTLY FLEXIBLE AND LAMINATED WITH CLEAR, ALL-WEATHER, CHEMICAL & UV RESISTANT FILM. EDGES SHALL BE TAPED WITH MATCHING TAPE TO PROTECT LABEL EDGES. VERBIAGE SHALL BE PRE PRINTED BY MACHINE. LABELS SHALL BE AFFIXED AT EVERY LOCATION ACCESSIBLE.
    - POWER CONDUCTORS SHALL HAVE ADHESIVE TYPE WRAP LABELS APPLIED INDICATING PANEL & CIRCUIT OF ORIGIN.
  - INSULATED CONDUCTORS SIZES #6 AND SMALLER SHALL HAVE FACTORY COLOR CODED INSULATION. SIZES #4 AND LARGER MAY BE EITHER FACTORY CODED OR CODED BY TAPE. COLOR TAPE SHALL BE APPLIED TO ALL CONDUCTORS AT 5' INTERVALS, WITH 6" (MINIMUM) "SWATCHES." COLORING SHALL BE AS FOLLOWS:  
120/208 VOLT THREE PHASE BY PHASE - BLACK/RED/BLUE  
N/B(G) - WHITE/GREEN  
  
COLOR CODING AND MARKING TAPE SHALL BE 3 MIL, SELF-ADHESIVE, 1 TO 2 INCHES WIDE.
- EQUIPMENT**
  - NO "WAFER" OR "PIGGYBACK" BREAKERS PERMITTED.
  - ELECTRICAL EQUIPMENT SHALL BE IDENTIFIED USING ENGRAVED, LAMINATED ACRYLIC OR MELAMINE LABELS PREPUNCHED OR PREDRILLED FOR RIVETING TO EQUIPMENT. WHITE LETTERS ON A DARK GRAY BACKGROUND WITH MINIMUM LETTER SIZE TO BE 3/8".  
ALL EQUIPMENT LISTED AS NEMA 1 OR LOCATED INSIDE OF BUILDING/STRUCTURE (NOT IN A CLASSIFIED AREA) SHALL HAVE IDENTIFICATION LABEL RIVETED TO ENCLOSURE. LABEL SHALL BE AS ABOVE EXCEPT WITH MINIMUM 1/2" LETTER HEIGHT.

**ELECTRICAL SYMBOL LEGEND**

- LIGHT FIXTURES - SEE LIGHT FIXTURE SCHEDULE FOR SPECIFICATIONS
- WALL MOUNTED LIGHT FIXTURE
- POLE MOUNTED LIGHT FIXTURE
- LINE VOLTAGE LIGHTING CONTROLS
- PHOTO CELL LIGHT CONTROL - WATTAGE NOTED
- ELECTRICAL DEVICES
- "WP" SIGNIFIES A WEATHERPROOF WEATHER RESISTANT GFCI RECEPTACLE, WALL DUPLEX, 120 VAC, SPECIFICATION GRADE, 20 AMP. UNO, PROVIDE WITH A METALLIC, "EXTRA DUTY", IN-USE TYPE, WET LOCATION LISTED COVER PLATE.
- GFCI TYPE RECEPTACLE, WALL DUPLEX, 120V, SPECIFICATION GRADE, 20 AMP. INSTALL AT 18" AFF TO C.L. (U.N.O.)
- NOTES & LINEWORK
- A-1,3,5 - PANEL AND CIRCUIT NUMBER DESIGNATION.
- A-1, C, NL, O - LIGHT FIXTURE DESIGNATION LEGEND:
  - A-1 PANEL/CIRCUIT DESIGNATION
  - a/ab SWITCHING CONTROL DESIGNATION
  - C FIXTURE DESIGNATION (SEE SCHEDULE)
  - EM/EX FIXTURE DESIGNATION (SEE SCHEDULE)
  - NL INDICATES 24 HOUR OPERATION SWITCHED AT PANEL. PROVIDE BREAKER RATED FOR SWITCHING DUTY
- ## SPECIFIC NOTE RELATIVE TO SINGLE CALL OUT, SEE SPECIFIC NOTE LEGEND. THESE NOTES ARE PROJECT WIDE.
- # KEY NOTE, SEE KEY NOTES ON EACH SHEET, THESE NOTES ARE ONLY APPLICABLE TO THOSE SHEETS ON WHICH THEY APPEAR.
- CONDUIT RUN (CONCEALED)
- - - CONDUIT RUN (IN SLAB OR GRADE)

**SPECIFIC NOTES**

- PROVIDE A SERVICE GROUND ACCORDING TO N.E.C. ARTICLE 250.52 OF THE N.E.C. MINIMUM INSTALLATION TO INCLUDE: BUILDING FOOTER/ FOUNDATION REINFORCING STEEL (20' OF #4 MIN. SIZE) TURNED UP OR OTHERWISE EXPOSED AT THE SERVICE WITH APPROVED CONNECTOR ATTACHMENT BONDING A #4 Cu GROUNDING CONDUCTOR TO THE STEEL; (2) COPPER CLAD DRIVEN ROD GROUNDS (MIN. 3/4" X 10" DEEP) WITH #6 COPPER GROUNDING CONDUCTOR, IF AVAILABLE ON PREMISES, ALSO, BOND: METAL COLD WATER PIPING AND METAL BUILDING FRAME WITH JUMPERS SIZED FROM 250.66, EQUIPMENT GROUNDING PER TABLE 250.122.

**LIGHT FIXTURE SCHEDULE**

TYPE	DESCRIPTION	MANUFACTURER	MODEL
C31	LED AREA FIXTURE, 6,100 LUMEN, 45 WATT, 3,000°K, TYPE 3 DISTRIBUTION, FULL CUTOFF (B1U0G2), MULTI-VOLT, DARK BRONZE FINISH, EPA=24SF. PROVIDE 2-3/8" TENNON SLIPFITTER. UNO, MOUNT AT 20' ON 25' DIRECT BURIAL CONCRETE POLE (5' IN GRADE).	GARDCO USI	P15-P-A03-730-T3M-PTF-UNV-BZ TII-25
C32	TWIN LED AREA FIXTURES, 6,100 LUMEN, 45 WATT, 3,000°K, TYPE 3 DISTRIBUTION, FULL CUTOFF (B1U0G2), MULTI-VOLT, DARK BRONZE FINISH, EPA=24SF PER FIXTURE. PROVIDE 2-3/8" TENNON SLIPFITTER TO MOUNT (2) FIXTURES @ 180'. UNO, MOUNT AT 20' ON 25' DIRECT BURIAL CONCRETE POLE (5' IN GRADE).	GARDCO USI	(2) P15-P-A03-730-T3M-PTF-UNV-BZ TII-25
C41	LED AREA FIXTURE, 6,200 LUMEN, 45 WATT, 3,000°K, TYPE 4 DISTRIBUTION, FULL CUTOFF (B1U0G2), MULTI-VOLT, DARK BRONZE FINISH, EPA=24SF. PROVIDE 2-3/8" TENNON SLIPFITTER. UNO, MOUNT AT 20' ON 25' DIRECT BURIAL CONCRETE POLE (5' IN GRADE).	GARDCO USI	P15-P-A03-730-T4S-AR1-UNV-BZ TII-25
C41H	LED AREA FIXTURE, 6,200 LUMEN, 45 WATT, 3,000°K, TYPE 4 DISTRIBUTION, FULL CUTOFF (B1U0G2), HOUSE SIDE SHIELD, MULTI-VOLT, DARK BRONZE FINISH, EPA=24SF. PROVIDE 2-3/8" TENNON SLIPFITTER. UNO, MOUNT AT 20' ON 25' DIRECT BURIAL CONCRETE POLE (5' IN GRADE).	GARDCO USI	P15-P-A03-730-T4S-AR1-UNV-HIS-BZ TII-25
D31	LED AREA FIXTURE, 7,900 LUMEN, 60 WATT, 3,000°K, TYPE 3 DISTRIBUTION, FULL CUTOFF (B1U0G2), MULTI-VOLT, DARK BRONZE FINISH, EPA=24SF. PROVIDE 2-3/8" TENNON SLIPFITTER. UNO, MOUNT AT 20' ON 25' DIRECT BURIAL CONCRETE POLE (5' IN GRADE).	GARDCO USI	P15-P-A04-730-T3M-AR1-UNV-BZ TII-25
E31	LED AREA FIXTURE, 9,300 LUMEN, 69 WATT, 3,000°K, TYPE 3 DISTRIBUTION, FULL CUTOFF (B2U0G2), MULTI-VOLT, DARK BRONZE FINISH, EPA=24SF. PROVIDE 2-3/8" TENNON SLIPFITTER. UNO, MOUNT AT 20' ON 25' DIRECT BURIAL CONCRETE POLE (5' IN GRADE).	GARDCO USI	P15-P-A05-730-T3M-AR1-UNV-BZ TII-25
E31H	LED AREA FIXTURE, 9,300 LUMEN, 69 WATT, 3,000°K, TYPE 3 DISTRIBUTION, FULL CUTOFF (B2U0G2), HOUSE SIDE SHIELD, MULTI-VOLT, DARK BRONZE FINISH, EPA=24SF. PROVIDE 2-3/8" TENNON SLIPFITTER. UNO, MOUNT AT 20' ON 25' DIRECT BURIAL CONCRETE POLE (5' IN GRADE).	GARDCO USI	P15-P-A05-730-T3M-AR1-UNV-HIS-BZ TII-25
E41	LED AREA FIXTURE, 9,400 LUMEN, 69 WATT, 3,000°K, TYPE 3 DISTRIBUTION, FULL CUTOFF (B2U0G2), MULTI-VOLT, DARK BRONZE FINISH, EPA=24SF. PROVIDE 2-3/8" TENNON SLIPFITTER. UNO, MOUNT AT 20' ON 25' DIRECT BURIAL CONCRETE POLE (5' IN GRADE).	GARDCO USI	P15-P-A05-730-T4S-AR1-UNV-BZ TII-25
G41H	LED AREA FIXTURE, 13,900 LUMEN, 104 WATT, 3,000°K, TYPE 3 DISTRIBUTION, FULL CUTOFF (B2U0G3), HOUSE SIDE SHIELD, MULTI-VOLT, DARK BRONZE FINISH, EPA=24SF. PROVIDE 2-3/8" TENNON SLIPFITTER. UNO, MOUNT AT 20' ON 25' DIRECT BURIAL CONCRETE POLE (5' IN GRADE).	GARDCO USI	P15-P-A07-730-T4S-AR1-UNV-HIS-BZ TII-25
WP	LED WALLPACK, 2,400 LUMEN, 22 WATT, 3,000°K, TYPE 4 DISTRIBUTION, FULL CUTOFF (B1U0G1), 120 VOLT, DARK BRONZE FINISH. MOUNT AT APPROXIMATELY 8' AFG AT LOCATION OF EXISTING EXTERIOR BUILDING LIGHT FIXTURE.	STONCO	LPW16-20-WW-G3-4-120-BZ

**NOTES**

- STARTUP AND COMMISSIONING OF ALL LIGHTING SYSTEM CONTROLS SHALL BE PERFORMED BY FACTORY TRAINED PERSONNEL WHO ARE FAMILIAR WITH THE OPERATION OF THE RESPECTIVE SYSTEMS. TRAINING SHALL BE PROVIDED TO OWNER'S STAFF SUCH THAT THE STAFF WILL BE FLUENT IN THE SYSTEMS OPERATION, MAINTENANCE, ALTERATION, ETC.
- CONTRACTOR TO PROVIDE PRICING BASED UPON THE SPECIFIED LIGHT FIXTURES. ALTERNATE FIXTURES WILL BE CONSIDERED DURING THE NORMAL COURSE OF SHOP DRAWING REVIEW. CUTSHEETS MUST INCLUDE INFORMATION TO BE ABLE TO COMPARE CONSTRUCTION, "GRADE," LAMPING, VOLTAGE, FINISHES, GENERAL APPEARANCE, DIMENSIONS, LENSING, ACCESSORIES, AND PHOTOMETRY TO THE SPECIFIED FIXTURES. ANY FIXTURE NOT MEETING THE DESIGN CRITERIA SHALL BE REJECTED. THE CONTRACTOR HAS SIXTY (60) DAYS FROM AWARD OF PROJECT TO SUBMIT LIGHT FIXTURE SHOP DRAWINGS AND GET THOSE SHOP DRAWINGS APPROVED. IF THE CONTRACTOR FAILS TO OBTAIN APPROVED SHOP DRAWINGS WITHIN THIS TIME PERIOD, THE CONTRACTOR SHALL PROVIDE THE FIXTURES AS SPECIFIED.
- WHERE FIXTURE IS NOTED TO BE INSTALLED AT 15', PROVIDE 20' DIRECT BURIAL CONCRETE POLE (5' IN GRADE) . UNO #TII-20

**ABBREVIATIONS**

AC	ALTERNATING CURRENT	LT/S	LIGHT/S
AF/G	ABOVE FINISH FLOOR/GRADE	N1	NEMA 1 (INDOOR ENCLOSURE)
AIC	AMPS INTERRUPTING CAPACITY	N3R	NEMA 3R (RAIN TIGHT ENCLOSURE)
B	BOND	N/NEUT	NEUTRAL
BFG	BELOW FINISH GRADE	NP	NON-PROTECTED
CB	CIRCUIT BREAKER	O/H	OVER HEAD
Cu	COPPER	P	POWER
DC	DIRECT CURRENT	PC	PHOTO CELL
DISC	DISCONNECT	RECEPT	RECEPTACLE/S
EMT	ELECTRICAL METALLIC TUBING (THIN WALL)	RS	RIGID STEEL CONDUIT
FCA	FAULT CURRENT AVAILABLE	S/N	SOLID NEUTRAL
FPL	FLORIDA POWER & LIGHT	SPD	SURGE PROTECTION DEVICE
FS	FUSED SWITCH	SS	STAINLESS STEEL
G	GROUND	XFMR	TRANSFORMER
GFI/GFCI	GROUND FAULT CIRCUIT INTERRUPTER	TC	TIME CLOCK
HD	HEAVY DUTY	UNO	UNLESS NOTED OTHERWISE
HGT	HEIGHT	UG	UNDERGROUND
JB	JUNCTION BOX	UL	UNDERWRITERS LABORATORIES
KVA	KILOVOLT AMPERE	WP	WEATHER PROOF
KW	KILOWATT	WR	WEATHER RESISTANT
LC	LIGHTING CONTACTOR		

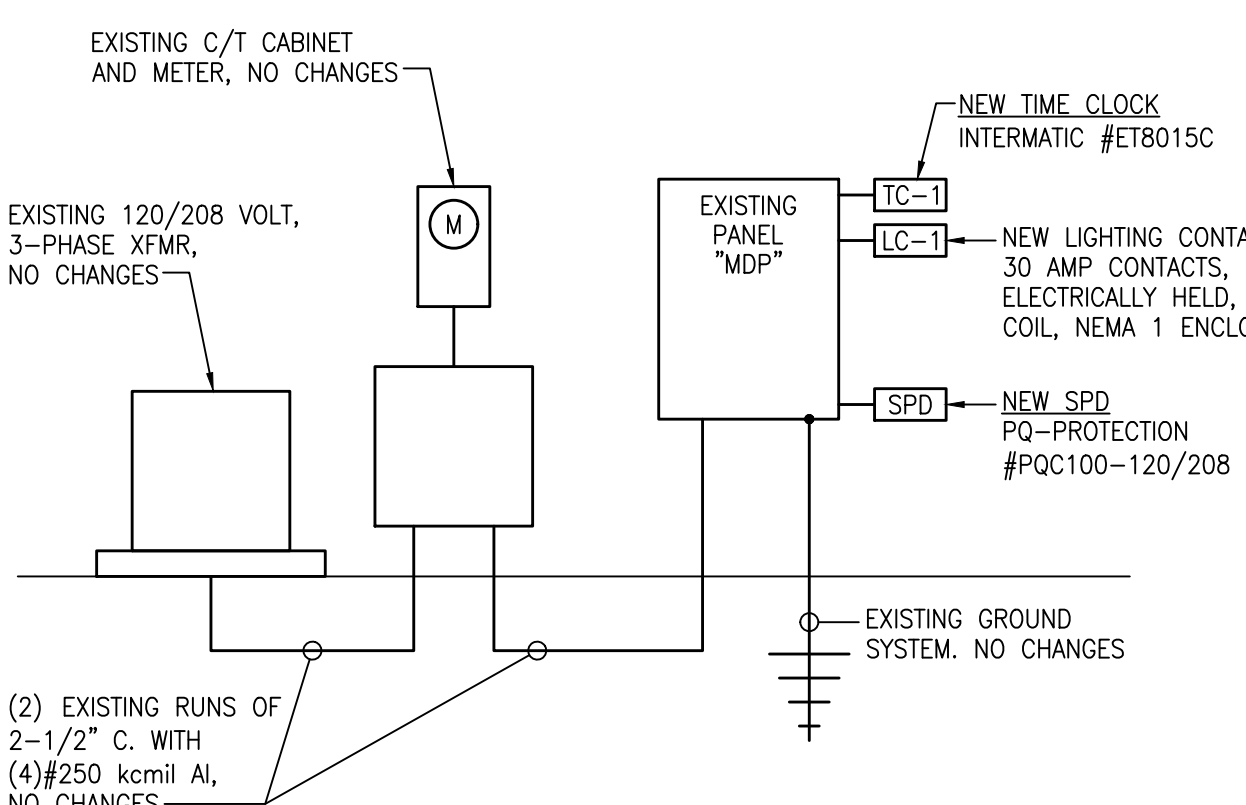

**POWER RISER DIAGRAM**  
SCALE: NONE

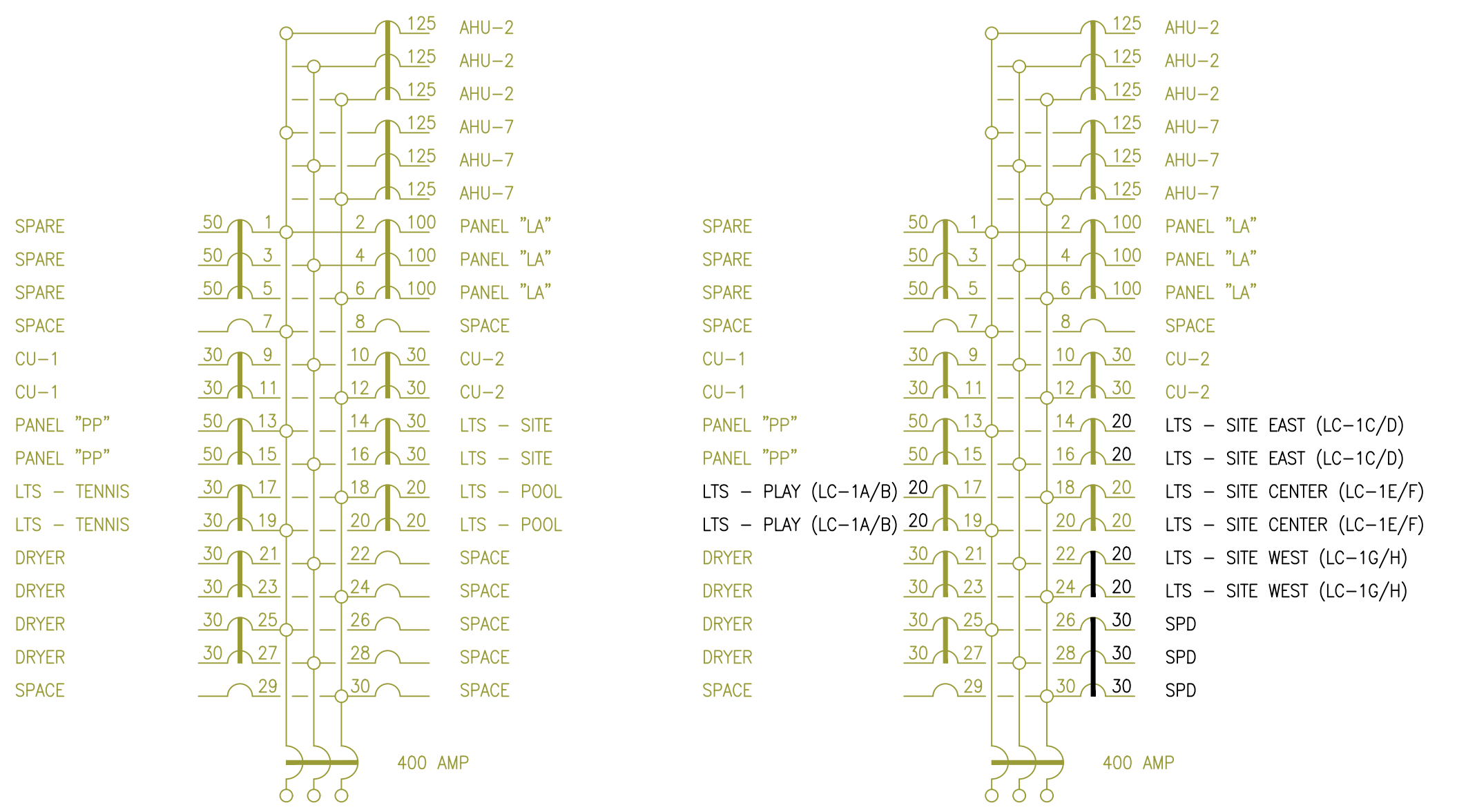

**EXISTING PANEL "MP" SCHEDULE**  
400 AMP BUS - MCB - 120/208V - 3 PHASE - S/N SURFACE MOUNTED - NEMA 1 PANEL BOARD (ITE "COP") WITH COPPER BUS.

**REWORKED PANEL "MP" SCHEDULE**  
400 AMP BUS - MCB - 120/208V - 3 PHASE - S/N SURFACE MOUNTED - NEMA 1 PANEL BOARD (ITE "COP") WITH COPPER BUS.

PANEL "MP"		
EXISTING DEMAND PER FP&L @ 125%	=	27.5 KVA
NEW SITE LIGHTING @ 125%	=	5.1 KVA
	=	32.6 KVA
	(√3 x 208) ÷	360 V
400 AMPS EXISTING	=	90.5 AMPS

**BURGESS BRANT**  
CONSULTING ENGINEERS  
1895 S. CLEVELAND AVENUE SUITE 229  
FORT MYERS, FL 33907  
(239) 274-0020 (239) 274-0021 (FAX)  
EMAIL: BBCE@BURGESSBRANT.COM  
CERTIFICATE OF AUTHORIZATION #6032  
JOSEPH W BROUGHTON, PE #63949  
MARK A BRANT, PE #54692

SET NO: [CIRCLE]

REVISIONS: [CIRCLE]

**MSA MOORE & SPENCE ARCHITECTS, P.A.**  
12613 NEW BRITANNY BLVD.  
FORT MYERS, FLORIDA 33907  
(239) 278-3520 FAX (239) 278-3519  
AR #0018983 / AR #0018935

COPYRIGHT 2021 / MOORE & SPENCE ARCHITECTS, P.A. / ALL RIGHTS RESERVED / UNAUTHORIZED REPRODUCTION OR MODIFICATION OF THESE PLANS OR DRAWINGS ARE STRICTLY PROHIBITED.

THE HORIZON APARTMENTS  
FOR THE HOUSING AUTHORITY OF  
THE CITY OF FORT MYERS  
FORT MYERS, LEE COUNTY, FLORIDA  
ELECTRICAL NOTES, SYMBOLS, SCHEDULES & RISER

JOB No:  
**21048**  
3/14/2022

SHEET No:  
[CIRCLE]

MS21-12





**KEY NOTES**

1. (2)#8 Cu, (1)#8 Cu-G IN 1" PVC.
2. (2)#10 Cu, (1)#10 Cu-G IN 1" PVC.
3. (2)#12 Cu, (1)#12 Cu-G IN 1" PVC.
4. REPLACE EXISTING WALL SCONCE WITH NEW FIXTURE. REUSE EXISTING CIRCUIT AND CONTROL.

SET NO:

REVISIONS:

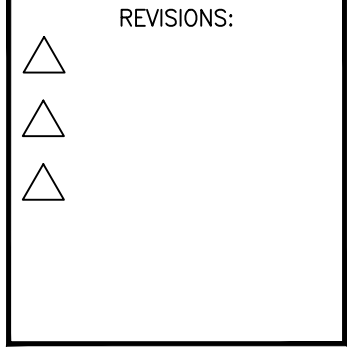

**MSA MOORE & SPENCE ARCHITECTS, P.A.**  
 12613 NEW BRITANNY BLVD.  
 FORT MYERS, FLORIDA 33907  
 (239) 278-3520 FAX (239) 278-3519  
 AR #0018983 / AR #0016305

**THE HORIZON APARTMENTS**  
 FOR THE HOUSING AUTHORITY OF  
 THE CITY OF FORT MYERS  
 FORT MYERS, LEE COUNTY, FLORIDA  
**PARTIAL SITE LIGHTING PLAN**

JOB No:

**21048**

3/14/2022

SHEET No:

**13**

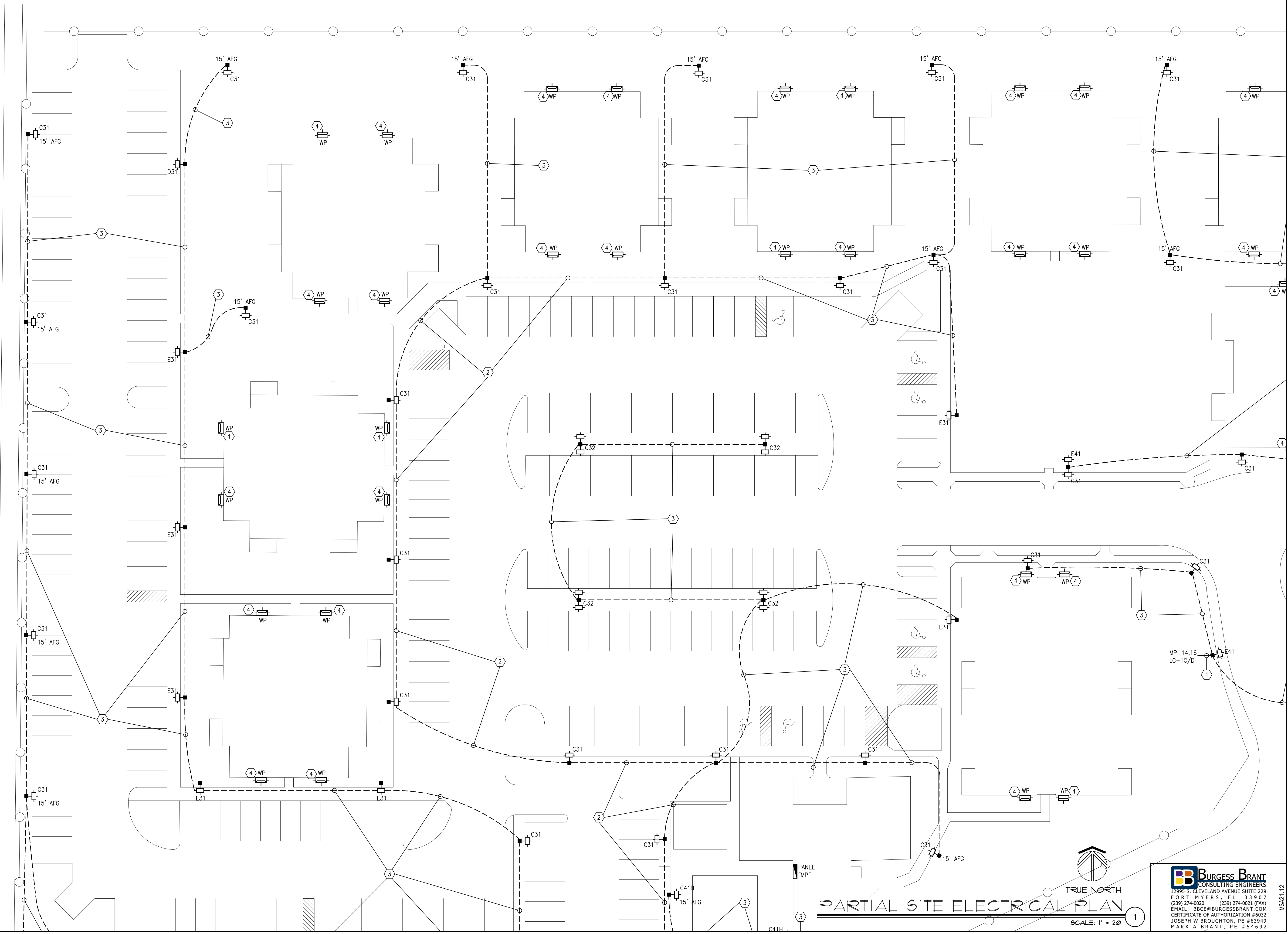

**PARTIAL SITE ELECTRICAL PLAN**

TRUE NORTH

SCALE: 1" = 20'

**BURGESS BRANT**  
 CONSULTING ENGINEERS  
 13995 S. CLEVELAND AVENUE SUITE 239  
 FORT MYERS, FL 33907  
 (239) 274-0020 (239) 274-0021 (FAX)  
 EMAIL: BBCE@BURGESSBRANT.COM  
 CERTIFICATE OF AUTHORIZATION #6032  
 JOSEPH W BROUGHTON, PE #63949  
 MARK A BRANT, PE #54692

COPYRIGHT 2021 / MOORE & SPENCE ARCHITECTS, P.A. / ALL RIGHTS RESERVED / UNAUTHORIZED REPRODUCTION OR MODIFICATION OF THESE PLANS OR DRAWINGS ARE STRICTLY PROHIBITED.

MS21.12



**KEY NOTES**

1. (2)#8 Cu, (1)#8 Cu-G IN 1" PVC.
2. (2)#10 Cu, (1)#10 Cu-G IN 1" PVC.
3. (2)#12 Cu, (1)#12 Cu-G IN 1" PVC.
4. REPLACE EXISTING WALL SCONCE WITH NEW FIXTURE. REUSE EXISTING CIRCUIT AND CONTROL.

SET NO:

REVISIONS:

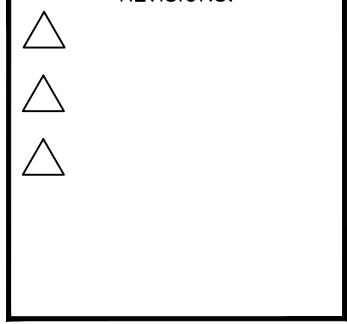

**MSA MOORE & SPENCE ARCHITECTS, P.A.**  
 12613 NEW BRITANNY BLVD.  
 FORT MYERS, FLORIDA 33907  
 (239) 278-3520 FAX (239) 278-3519  
 AR #0018983 / AR #0018305

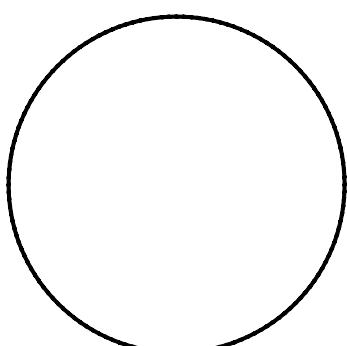

**THE HORIZON APARTMENTS**  
 FOR THE HOUSING AUTHORITY OF  
 THE CITY OF FORT MYERS  
 FORT MYERS, LEE COUNTY, FLORIDA  
**PARTIAL SITE LIGHTING PLAN**

JOB No:  
**21048**  
 3/14/2022

SHEET No:  
**E4**

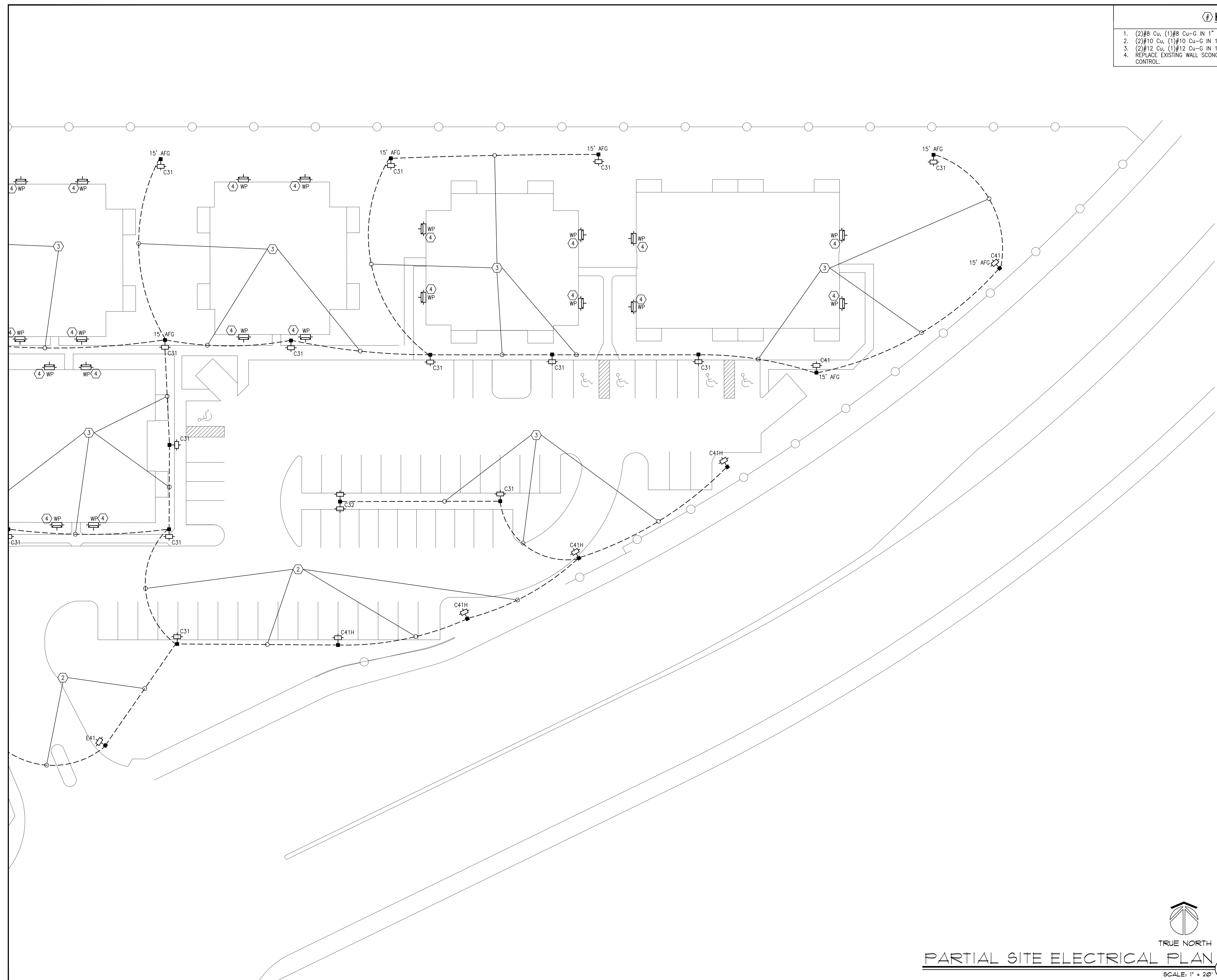

**PARTIAL SITE ELECTRICAL PLAN**

SCALE: 1" = 20'

**BURGESS BRANT**  
 CONSULTING ENGINEERS  
 1395 S. CLEVELAND AVENUE SUITE 239  
 FORT MYERS, FL 33907  
 (239) 274-0020 (239) 274-0021 (FAX)  
 EMAIL: BBCE@BURGESSBRANT.COM  
 CERTIFICATE OF AUTHORIZATION #6032  
 JOSEPH W BROUGHTON, PE #63949  
 MARK A BRANT, PE #54692

MS21.12

COPYRIGHT 2021 / MOORE & SPENCE ARCHITECTS, P.A. / ALL RIGHTS RESERVED / UNAUTHORIZED REPRODUCTION OR MODIFICATION OF THESE PLANS OR DRAWINGS ARE STRICTLY PROHIBITED.

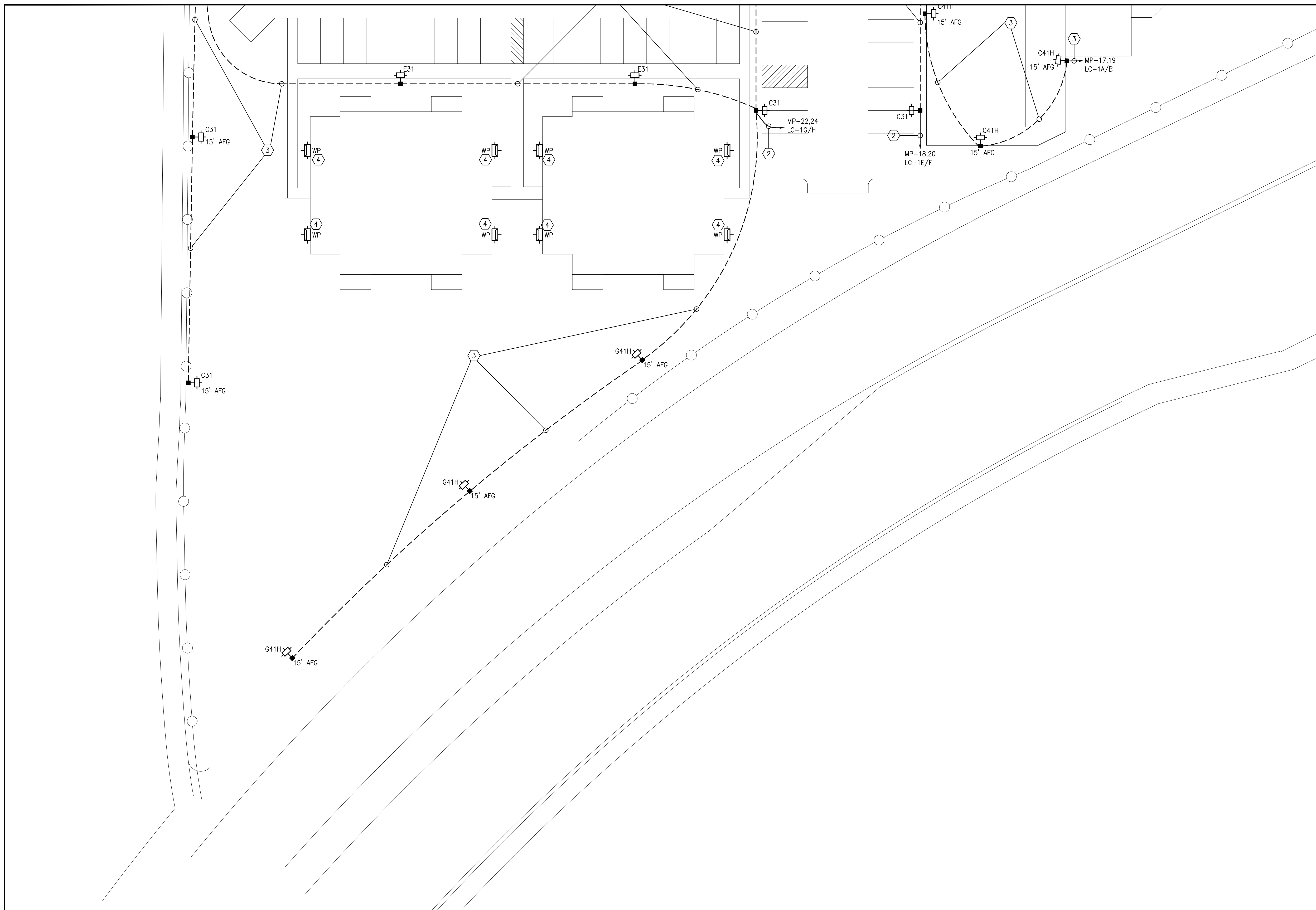

- KEY NOTES**
- (2)#8 Cu, (1)#8 Cu-G IN 1" PVC.
  - (2)#10 Cu, (1)#10 Cu-G IN 1" PVC.
  - (2)#12 Cu, (1)#12 Cu-G IN 1" PVC.
  - REPLACE EXISTING WALL SCONCE WITH NEW FIXTURE. REUSE EXISTING CIRCUIT AND CONTROL.

SET NO:

REVISIONS:

▲

▲

▲

**MSA MOORE & SPENCE ARCHITECTS, P.A.**  
 12613 NEW BRITANNY BLVD.  
 FORT MYERS, FLORIDA 33907  
 (239) 278-3520 FAX (239) 278-3519  
 AR #0018983 / AR #0016305

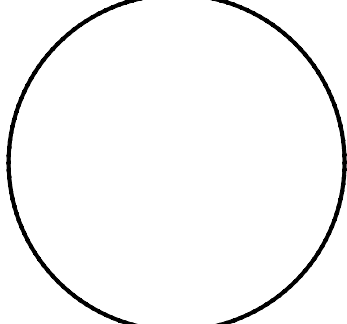

COPYRIGHT 2021 / MOORE & SPENCE ARCHITECTS, P.A. / ALL RIGHTS RESERVED / UNAUTHORIZED REPRODUCTION OR MODIFICATION OF THESE PLANS OR DRAWINGS ARE STRICTLY PROHIBITED.

A SITE LIGHTING PROJECT AT  
**THE HORIZON APARTMENTS**  
 FOR THE HOUSING AUTHORITY OF  
 THE CITY OF FORT MYERS  
 FORT MYERS, LEE COUNTY, FLORIDA

**PARTIAL SITE LIGHTING PLAN**

JOB No:  
**21048**  
 3/14/2022

SHEET No:  
**15**



**PARTIAL SITE ELECTRICAL PLAN**

SCALE: 1" = 20'

**BURGESS BRANT**  
 CONSULTING ENGINEERS  
 1395 S. CLEVELAND AVENUE SUITE 239  
 FORT MYERS, FL 33907  
 (239) 274-0020 (239) 274-0021 (FAX)  
 EMAIL: BBCE@BURGESSBRANT.COM  
 CERTIFICATE OF AUTHORIZATION #6032  
 JOSEPH W BROUGHTON, PE #63949  
 MARK A BRANT, PE #54692

MS21.12



SET NO:

REVISIONS:

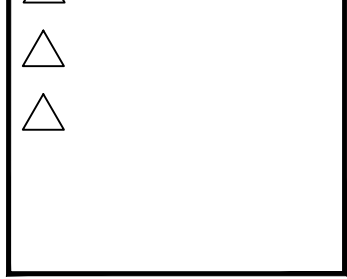

MSA MOORE & SPENCE ARCHITECTS, P.A.  
12613 NEW BRITANNY BLVD.  
FORT MYERS, FLORIDA 33907  
(239) 278-3520 FAX (239) 278-3519  
AR #0018983 / AR #0016335

THE HORIZON APARTMENTS  
FOR THE HOUSING AUTHORITY OF  
THE CITY OF FORT MYERS  
FORT MYERS, LEE COUNTY, FLORIDA

OVERALL SITE LIGHTING PLAN

JOB No:

21048

3/14/2022

SHEET No:

SL1

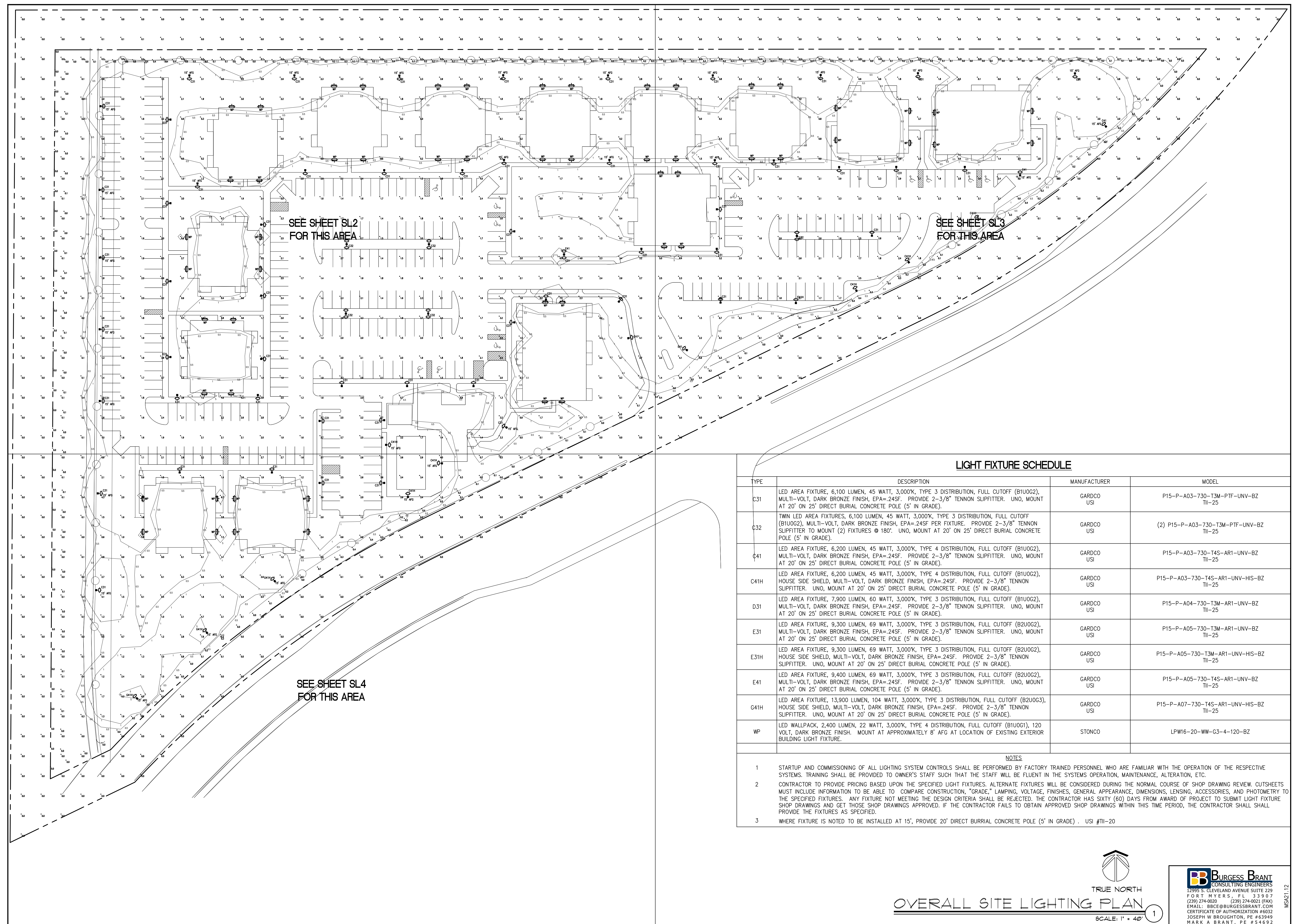

LIGHT FIXTURE SCHEDULE

TYPE	DESCRIPTION	MANUFACTURER	MODEL
C31	LED AREA FIXTURE, 6,100 LUMEN, 45 WATT, 3,000K, TYPE 3 DISTRIBUTION, FULL CUTOFF (B1U0G2), MULTI-VOLT, DARK BRONZE FINISH, EPA=24SF. PROVIDE 2-3/8" TENNON SLIPFITTER. UNO, MOUNT AT 20' ON 25' DIRECT BURIAL CONCRETE POLE (5' IN GRADE).	GARDCO USI	P15-P-A03-730-T3M-PTF-UNV-BZ TII-25
C32	TWIN LED AREA FIXTURES, 6,100 LUMEN, 45 WATT, 3,000K, TYPE 3 DISTRIBUTION, FULL CUTOFF (B1U0G2), MULTI-VOLT, DARK BRONZE FINISH, EPA=24SF PER FIXTURE. PROVIDE 2-3/8" TENNON SLIPFITTER TO MOUNT (2) FIXTURES @ 180°. UNO, MOUNT AT 20' ON 25' DIRECT BURIAL CONCRETE POLE (5' IN GRADE).	GARDCO USI	(2) P15-P-A03-730-T3M-PTF-UNV-BZ TII-25
C41	LED AREA FIXTURE, 6,200 LUMEN, 45 WATT, 3,000K, TYPE 4 DISTRIBUTION, FULL CUTOFF (B1U0G2), MULTI-VOLT, DARK BRONZE FINISH, EPA=24SF. PROVIDE 2-3/8" TENNON SLIPFITTER. UNO, MOUNT AT 20' ON 25' DIRECT BURIAL CONCRETE POLE (5' IN GRADE).	GARDCO USI	P15-P-A03-730-T4S-AR1-UNV-BZ TII-25
C41H	LED AREA FIXTURE, 6,200 LUMEN, 45 WATT, 3,000K, TYPE 4 DISTRIBUTION, FULL CUTOFF (B1U0G2), HOUSE SIDE SHIELD, MULTI-VOLT, DARK BRONZE FINISH, EPA=24SF. PROVIDE 2-3/8" TENNON SLIPFITTER. UNO, MOUNT AT 20' ON 25' DIRECT BURIAL CONCRETE POLE (5' IN GRADE).	GARDCO USI	P15-P-A03-730-T4S-AR1-UNV-HIS-BZ TII-25
D31	LED AREA FIXTURE, 7,900 LUMEN, 60 WATT, 3,000K, TYPE 3 DISTRIBUTION, FULL CUTOFF (B1U0G2), MULTI-VOLT, DARK BRONZE FINISH, EPA=24SF. PROVIDE 2-3/8" TENNON SLIPFITTER. UNO, MOUNT AT 20' ON 25' DIRECT BURIAL CONCRETE POLE (5' IN GRADE).	GARDCO USI	P15-P-A04-730-T3M-AR1-UNV-BZ TII-25
E31	LED AREA FIXTURE, 9,300 LUMEN, 69 WATT, 3,000K, TYPE 3 DISTRIBUTION, FULL CUTOFF (B2U0G2), MULTI-VOLT, DARK BRONZE FINISH, EPA=24SF. PROVIDE 2-3/8" TENNON SLIPFITTER. UNO, MOUNT AT 20' ON 25' DIRECT BURIAL CONCRETE POLE (5' IN GRADE).	GARDCO USI	P15-P-A05-730-T3M-AR1-UNV-BZ TII-25
E31H	LED AREA FIXTURE, 9,300 LUMEN, 69 WATT, 3,000K, TYPE 3 DISTRIBUTION, FULL CUTOFF (B2U0G2), HOUSE SIDE SHIELD, MULTI-VOLT, DARK BRONZE FINISH, EPA=24SF. PROVIDE 2-3/8" TENNON SLIPFITTER. UNO, MOUNT AT 20' ON 25' DIRECT BURIAL CONCRETE POLE (5' IN GRADE).	GARDCO USI	P15-P-A05-730-T3M-AR1-UNV-HIS-BZ TII-25
E41	LED AREA FIXTURE, 9,400 LUMEN, 69 WATT, 3,000K, TYPE 3 DISTRIBUTION, FULL CUTOFF (B2U0G2), MULTI-VOLT, DARK BRONZE FINISH, EPA=24SF. PROVIDE 2-3/8" TENNON SLIPFITTER. UNO, MOUNT AT 20' ON 25' DIRECT BURIAL CONCRETE POLE (5' IN GRADE).	GARDCO USI	P15-P-A05-730-T4S-AR1-UNV-BZ TII-25
G41H	LED AREA FIXTURE, 13,900 LUMEN, 104 WATT, 3,000K, TYPE 3 DISTRIBUTION, FULL CUTOFF (B2U0G3), HOUSE SIDE SHIELD, MULTI-VOLT, DARK BRONZE FINISH, EPA=24SF. PROVIDE 2-3/8" TENNON SLIPFITTER. UNO, MOUNT AT 20' ON 25' DIRECT BURIAL CONCRETE POLE (5' IN GRADE).	GARDCO USI	P15-P-A07-730-T4S-AR1-UNV-HIS-BZ TII-25
WP	LED WALLPACK, 2,400 LUMEN, 22 WATT, 3,000K, TYPE 4 DISTRIBUTION, FULL CUTOFF (B1U0G1), 120 VOLT, DARK BRONZE FINISH. MOUNT AT APPROXIMATELY 8' AFG AT LOCATION OF EXISTING EXTERIOR BUILDING LIGHT FIXTURE.	STONCO	LPW16-20-WW-G3-4-120-BZ

NOTES

- 1 STARTUP AND COMMISSIONING OF ALL LIGHTING SYSTEM CONTROLS SHALL BE PERFORMED BY FACTORY TRAINED PERSONNEL WHO ARE FAMILIAR WITH THE OPERATION OF THE RESPECTIVE SYSTEMS. TRAINING SHALL BE PROVIDED TO OWNER'S STAFF SUCH THAT THE STAFF WILL BE FLUENT IN THE SYSTEMS OPERATION, MAINTENANCE, ALTERATION, ETC.
- 2 CONTRACTOR TO PROVIDE PRICING BASED UPON THE SPECIFIED LIGHT FIXTURES. ALTERNATE FIXTURES WILL BE CONSIDERED DURING THE NORMAL COURSE OF SHOP DRAWING REVIEW. CUTSHEETS MUST INCLUDE INFORMATION TO BE ABLE TO COMPARE CONSTRUCTION, "GRADE," LAMPING, VOLTAGE, FINISHES, GENERAL APPEARANCE, DIMENSIONS, LENSING, ACCESSORIES, AND PHOTOMETRY TO THE SPECIFIED FIXTURES. ANY FIXTURE NOT MEETING THE DESIGN CRITERIA SHALL BE REJECTED. THE CONTRACTOR HAS SIXTY (60) DAYS FROM AWARD OF PROJECT TO SUBMIT LIGHT FIXTURE SHOP DRAWINGS AND GET THOSE SHOP DRAWINGS APPROVED. IF THE CONTRACTOR FAILS TO OBTAIN APPROVED SHOP DRAWINGS WITHIN THIS TIME PERIOD, THE CONTRACTOR SHALL PROVIDE THE FIXTURES AS SPECIFIED.
- 3 WHERE FIXTURE IS NOTED TO BE INSTALLED AT 15', PROVIDE 20' DIRECT BURIAL CONCRETE POLE (5' IN GRADE). USI #TII-20



TRUE NORTH

OVERALL SITE LIGHTING PLAN

SCALE: 1" = 40'

**BURGESS BRANT**  
CONSULTING ENGINEERS  
1399 S. CLEVELAND AVENUE SUITE 239  
FORT MYERS, FL 33907  
(239) 274-0020 (239) 274-0021 (FAX)  
EMAIL: BBCE@BURGESSBRANT.COM  
CERTIFICATE OF AUTHORIZATION #6032  
JOSEPH W BROUGHTON, PE #63949  
MARK A BRANT, PE #54692

MSA21.12



SET NO:

REVISIONS:

MSA MOORE & SPENCE ARCHITECTS, P.A.  
12613 NEW BRITANNY BLVD.  
FORT MYERS, FLORIDA 33907  
(239) 278-3520 FAX (239) 278-3519  
AR #0018983 / AR #0016305

THE HORIZON APARTMENTS  
FOR THE HOUSING AUTHORITY OF  
THE CITY OF FORT MYERS  
FORT MYERS, LEE COUNTY, FLORIDA

PARTIAL SITE LIGHTING PLAN

JOB No:  
21048  
3/14/2022

SHEET No:  
SL2

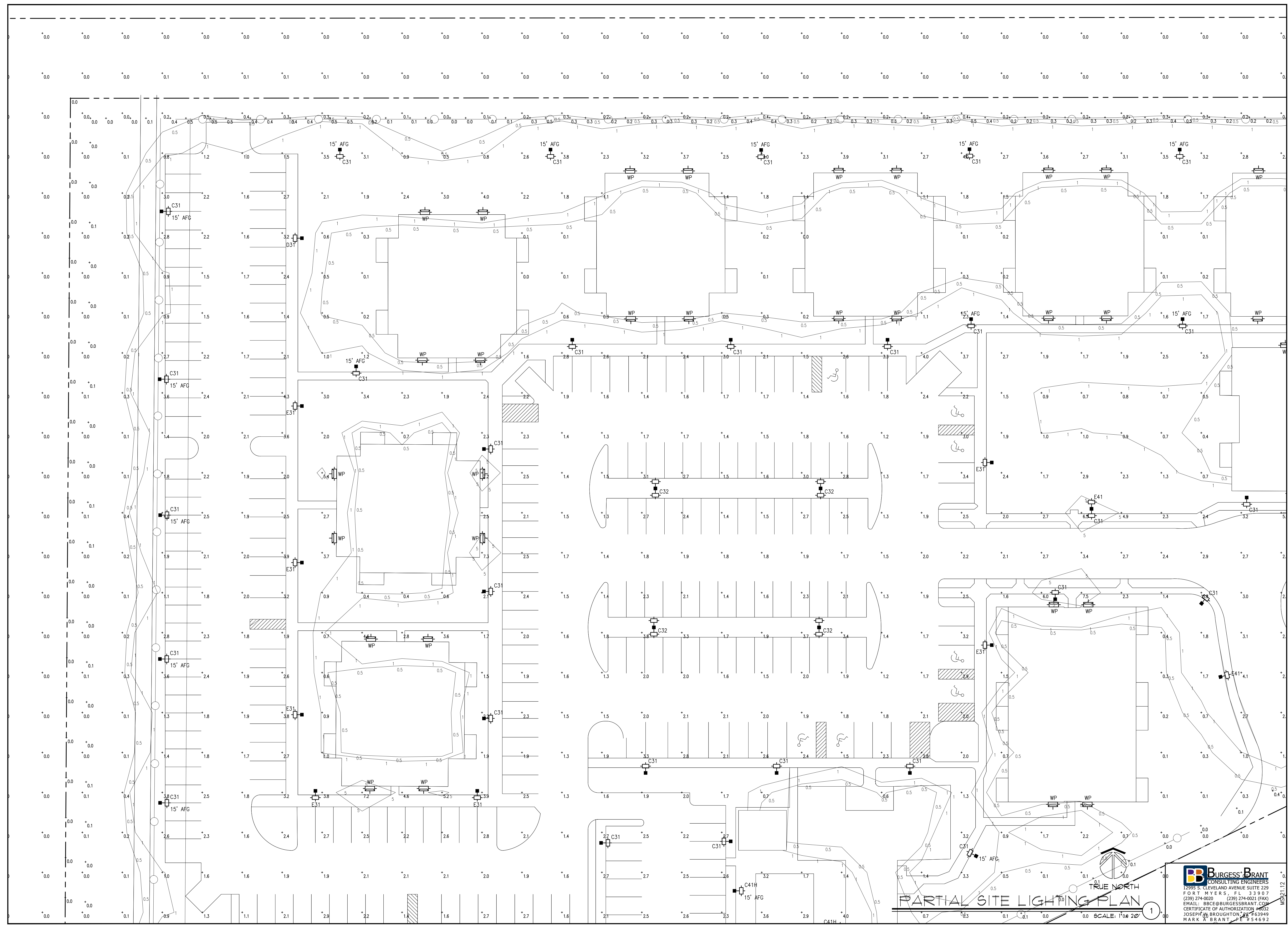

COPYRIGHT 2021 / MOORE & SPENCE ARCHITECTS, P.A. / ALL RIGHTS RESERVED / UNAUTHORIZED REPRODUCTION OR MODIFICATION OF THESE PLANS OR DRAWINGS ARE STRICTLY PROHIBITED.

**BURGESS BRANT**  
CONSULTING ENGINEERS  
12995 S. CLEVELAND AVENUE SUITE 239  
FORT MYERS, FL 33907  
(239) 274-0020 (239) 274-0021 (FAX)  
EMAIL: BBCE@BURGESSBRANT.COM  
CERTIFICATE OF AUTHORIZATION #0032  
JOSEPH W. BROUGHTON, P.E. #63949  
MARK A. BRANT, P.E. #54692

PARTIAL SITE LIGHTING PLAN  
SCALE: 1"=0'-20"  
1



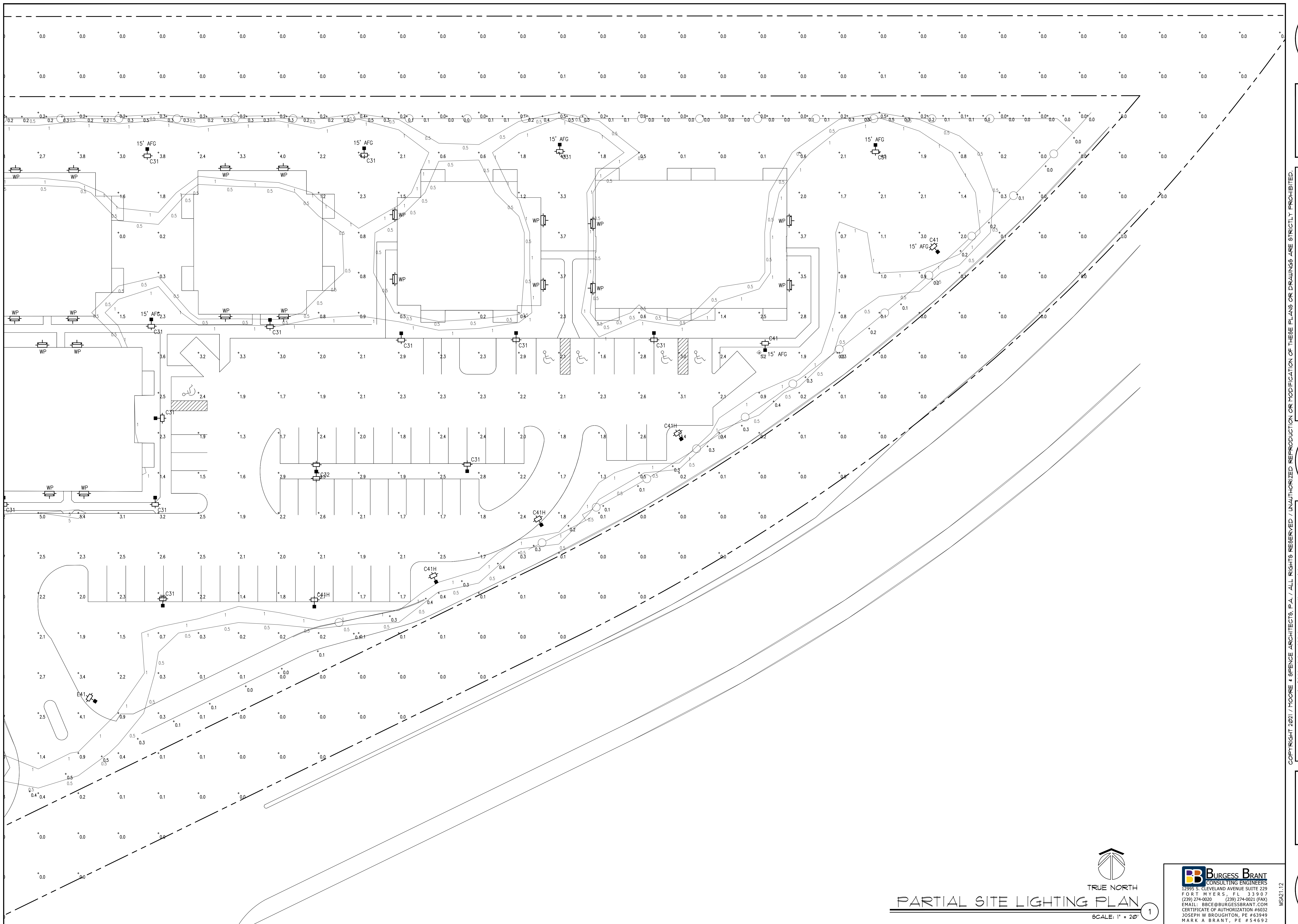

SET NO:

REVISIONS:

- △
- △
- △

**MSA MOORE & SPENCE ARCHITECTS, P.A.**  
 12613 NEW BRITANNY BLVD.  
 FORT MYERS, FLORIDA 33907  
 (239) 278-3520 FAX (239) 278-3519  
 AR #0018983 / AR #0016305

THE HORIZON APARTMENTS  
 FOR THE HOUSING AUTHORITY OF  
 THE CITY OF FORT MYERS  
 FORT MYERS, LEE COUNTY, FLORIDA

PARTIAL SITE LIGHTING PLAN

JOB No:  
**21048**  
 3/14/2022

SHEET No:  
**SL3**



**PARTIAL SITE LIGHTING PLAN**

SCALE: 1" = 20'

**BURGESS BRANT**  
 CONSULTING ENGINEERS  
 1395 S. CLEVELAND AVENUE SUITE 239  
 FORT MYERS, FL 33907  
 (239) 274-0020 (239) 274-0021 (FAX)  
 EMAIL: BBCE@BURGESSBRANT.COM  
 CERTIFICATE OF AUTHORIZATION #6032  
 JOSEPH W BROUGHTON, PE #63949  
 MARK A BRANT, PE #54692

MS21.12

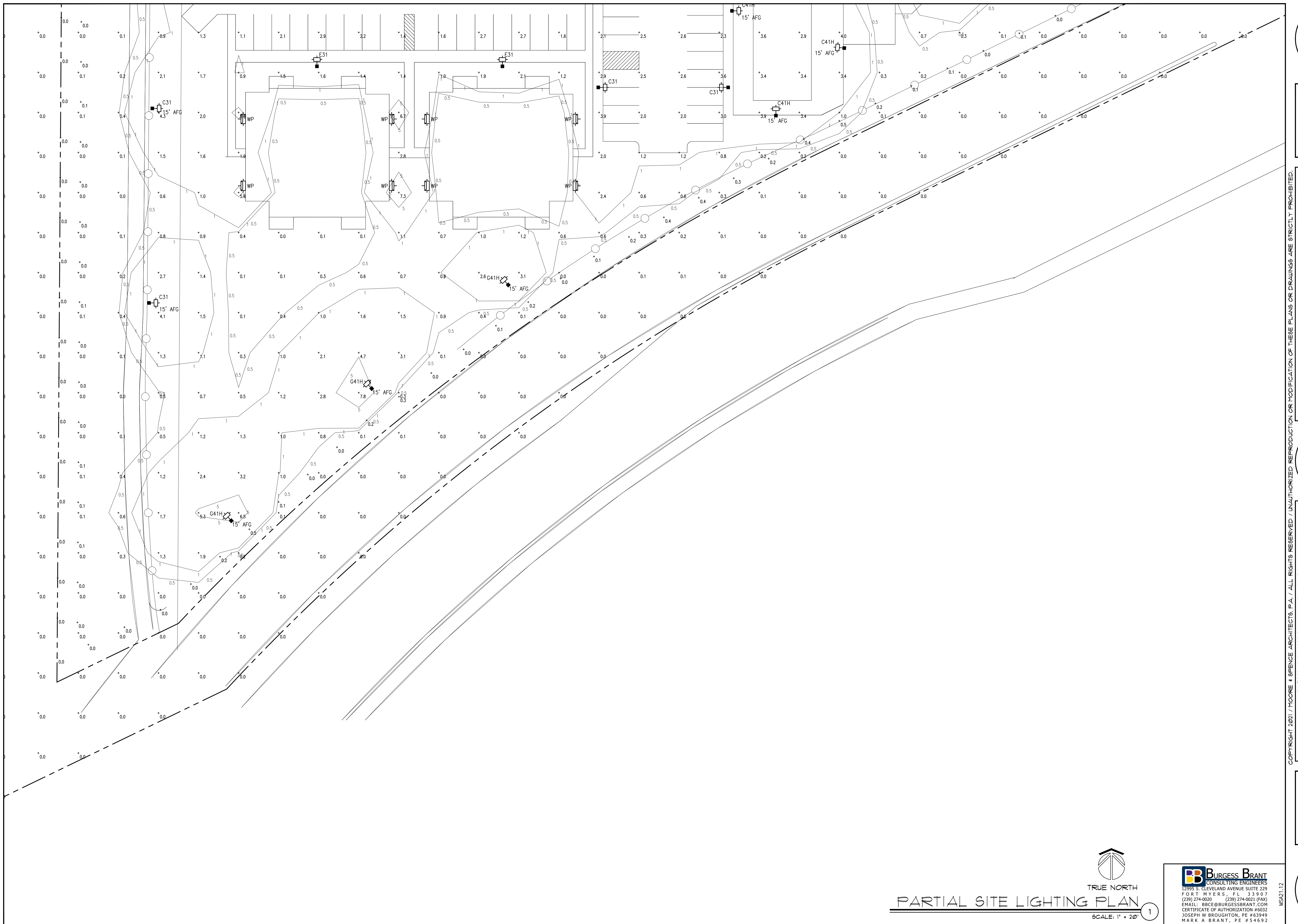

SET NO:

REVISIONS:

**MSA MOORE & SPENCE ARCHITECTS, P.A.**  
 12613 NEW BRITANNY BLVD.  
 FORT MYERS, FLORIDA 33907  
 (239) 278-3520 FAX (239) 278-3519  
 AR #0018983 / AR #0016305

A SITE LIGHTING PROJECT AT

**THE HORIZON APARTMENTS**  
 FOR THE HOUSING AUTHORITY OF  
 THE CITY OF FORT MYERS  
 FORT MYERS, LEE COUNTY, FLORIDA

JOB No:  
**21048**  
 3/14/2022

SHEET No:  
**SL4**



TRUE NORTH

**PARTIAL SITE LIGHTING PLAN**

SCALE: 1" = 20'

**BURGESS BRANT**  
 CONSULTING ENGINEERS  
 1395 S. CLEVELAND AVENUE SUITE 239  
 FORT MYERS, FL 33907  
 (239) 274-0020 (239) 274-0021 (FAX)  
 EMAIL: BBCE@BURGESSBRANT.COM  
 CERTIFICATE OF AUTHORIZATION #6032  
 JOSEPH W BROUGHTON, PE #63949  
 MARK A BRANT, PE #54692

COPYRIGHT 2021 / MOORE & SPENCE ARCHITECTS, P.A. / ALL RIGHTS RESERVED / UNAUTHORIZED REPRODUCTION OR MODIFICATION OF THESE PLANS OR DRAWINGS ARE STRICTLY PROHIBITED.

MS21.12

**U.S. Department of Housing and  
Urban Development**  
Office of Public and Indian Housing

**Instructions to Bidders for Contracts  
Public and Indian Housing Programs**



# Instructions to Bidders for Contracts

## Public and Indian Housing Programs

### Table of Contents

Clause	Page
1. Bid Preparation and Submission	1
2. Explanations and Interpretations to Prospective Bidders	1
3. Amendments to Invitations for Bids	1
4. Responsibility of Prospective Contractor	1
5. Late Submissions, Modifications, and Withdrawal of Bids	1
6. Bid Opening	2
7. Service of Protest	2
8. Contract Award	2
9. Bid Guarantee	3
10. Assurance of Completion	3
11. Preconstruction Conference	3
12. Indian Preference Requirements	3

### 1. Bid Preparation and Submission

(a) Bidders are expected to examine the specifications, drawings, all instructions, and, if applicable, the construction site (see also the contract clause entitled **Site Investigation and Conditions Affecting the Work** of the *General Conditions of the Contract for Construction*). Failure to do so will be at the bidders' risk.

(b) All bids must be submitted on the forms provided by the Public Housing Agency/Indian Housing Authority (PHA/IHA). Bidders shall furnish all the information required by the solicitation. Bids must be signed and the bidder's name typed or printed on the bid sheet and each continuation sheet which requires the entry of information by the bidder. Erasures or other changes must be initialed by the person signing the bid. Bids signed by an agent shall be accompanied by evidence of that agent's authority. (Bidders should retain a copy of their bid for their records.)

(c) Bidders must submit as part of their bid a completed form HUD-5369-A, "Representations, Certifications, and Other Statements of Bidders."

(d) All bid documents shall be sealed in an envelope which shall be clearly marked with the words "Bid Documents," the Invitation for Bids (IFB) number, any project or other identifying number, the bidder's name, and the date and time for receipt of bids.

(e) If this solicitation requires bidding on all items, failure to do so will disqualify the bid. If bidding on all items is not required, bidders should insert the words "No Bid" in the space provided for any item on which no price is submitted.

(f) Unless expressly authorized elsewhere in this solicitation, alternate bids will not be considered.

(g) Unless expressly authorized elsewhere in this solicitation, bids submitted by telegraph or facsimile (fax) machines will not be considered.

(h) If the proposed contract is for a Mutual Help project (as described in 24 CFR Part 905, Subpart E) that involves Mutual Help contributions of work, material, or equipment, supplemental information regarding the bid advertisement is provided as an attachment to this solicitation.

### 2. Explanations and Interpretations to Prospective Bidders

(a) Any prospective bidder desiring an explanation or interpretation of the solicitation, specifications, drawings, etc., must request it at least 7 days before the scheduled time for bid opening. Requests may be oral or written. Oral requests must be confirmed in writing. The only oral clarifications that will be provided will be those clearly related to solicitation procedures, i.e., not substantive technical information. No other oral explanation or interpretation will be provided. Any information given a prospective bidder concerning this solicitation will be furnished promptly to all other prospective bidders as a written amendment to the solicitation, if that information is necessary in submitting bids, or if the lack of it would be prejudicial to other prospective bidders.

(b) Any information obtained by, or provided to, a bidder other than by formal amendment to the solicitation shall not constitute a change to the solicitation.

### 3. Amendments to Invitations for Bids

(a) If this solicitation is amended, then all terms and conditions which are not modified remain unchanged.

(b) Bidders shall acknowledge receipt of any amendment to this solicitation (1) by signing and returning the amendment, (2) by identifying the amendment number and date on the bid form, or (3) by letter, telegram, or facsimile, if those methods are authorized in the solicitation. The PHA/IHA must receive acknowledgement by the time and at the place specified for receipt of bids. Bids which fail to acknowledge the bidder's receipt of any amendment will result in the rejection of the bid if the amendment(s) contained information which substantively changed the PHA's/IHA's requirements.

(c) Amendments will be on file in the offices of the PHA/IHA and the Architect at least 7 days before bid opening.

### 4. Responsibility of Prospective Contractor

(a) The PHA/IHA will award contracts only to responsible prospective contractors who have the ability to perform successfully under the terms and conditions of the proposed contract. In determining the responsibility of a bidder, the PHA/IHA will consider such matters as the bidder's:

- (1) Integrity;
- (2) Compliance with public policy;
- (3) Record of past performance; and
- (4) Financial and technical resources (including construction and technical equipment).

(b) Before a bid is considered for award, the bidder may be requested by the PHA/IHA to submit a statement or other documentation regarding any of the items in paragraph (a) above. Failure by the bidder to provide such additional information shall render the bidder nonresponsible and ineligible for award.

## 5. Late Submissions, Modifications, and Withdrawal of Bids

(a) Any bid received at the place designated in the solicitation after the exact time specified for receipt will not be considered unless it is received before award is made and it:

(1) Was sent by registered or certified mail not later than the fifth calendar day before the date specified for receipt of offers (e.g., an offer submitted in response to a solicitation requiring receipt of offers by the 20th of the month must have been mailed by the 15th);

(2) Was sent by mail, or if authorized by the solicitation, was sent by telegram or via facsimile, and it is determined by the PHA/IHA that the late receipt was due solely to mishandling by the PHA/IHA after receipt at the PHA/IHA; or

(3) Was sent by U.S. Postal Service Express Mail Next Day Service - Post Office to Addressee, not later than 5:00 p.m. at the place of mailing two working days prior to the date specified for receipt of proposals. The term "working days" excludes weekends and observed holidays.

(b) Any modification or withdrawal of a bid is subject to the same conditions as in paragraph (a) of this provision.

(c) The only acceptable evidence to establish the date of mailing of a late bid, modification, or withdrawal sent either by registered or certified mail is the U.S. or Canadian Postal Service postmark both on the envelope or wrapper and on the original receipt from the U.S. or Canadian Postal Service. Both postmarks must show a legible date or the bid, modification, or withdrawal shall be processed as if mailed late. "Postmark" means a printed, stamped, or otherwise placed impression (exclusive of a postage meter machine impression) that is readily identifiable without further action as having been supplied and affixed by employees of the U.S. or Canadian Postal Service on the date of mailing. Therefore, bidders should request the postal clerk to place a hand cancellation bull's-eye postmark on both the receipt and the envelope or wrapper.

(d) The only acceptable evidence to establish the time of receipt at the PHA/IHA is the time/date stamp of PHA/IHA on the proposal wrapper or other documentary evidence of receipt maintained by the PHA/IHA.

(e) The only acceptable evidence to establish the date of mailing of a late bid, modification, or withdrawal sent by Express Mail Next Day Service-Post Office to Addressee is the date entered by the post office receiving clerk on the "Express Mail Next Day Service-Post Office to Addressee" label and the postmark on both the envelope or wrapper and on the original receipt from the U.S. Postal Service. "Postmark" has the same meaning as defined in paragraph (c) of this provision, excluding postmarks of the Canadian Postal Service. Therefore, bidders should request the postal clerk to place a legible hand cancellation bull's eye postmark on both the receipt and Failure by a bidder to acknowledge receipt of the envelope or wrapper.

(f) Notwithstanding paragraph (a) of this provision, a late modification of an otherwise successful bid that makes its terms more favorable to the PHA/IHA will be considered at any time it is received and may be accepted.

(g) Bids may be withdrawn by written notice, or if authorized by this solicitation, by telegram (including mailgram) or facsimile machine transmission received at any time before the exact time set for opening of bids; provided that written confirmation of telegraphic or facsimile withdrawals over the signature of the bidder is mailed and postmarked prior to the specified bid opening time. A bid may be withdrawn in person by a bidder or its authorized representative if, before the exact time set for opening of bids, the identity of the person requesting withdrawal is established and the person signs a receipt for the bid.

## 6. Bid Opening

All bids received by the date and time of receipt specified in the solicitation will be publicly opened and read. The time and place of opening will be as specified in the solicitation. Bidders and other interested persons may be present.

## 7. Service of Protest

(a) Definitions. As used in this provision:

"Interested party" means an actual or prospective bidder whose direct economic interest would be affected by the award of the contract.

"Protest" means a written objection by an interested party to this solicitation or to a proposed or actual award of a contract pursuant to this solicitation.

(b) Protests shall be served on the Contracting Officer by obtaining written and dated acknowledgement from —

[Contracting Officer designate the official or location where a protest may be served on the Contracting Officer]

(c) All protests shall be resolved in accordance with the PHA's/IHA's protest policy and procedures, copies of which are maintained at the PHA/IHA.

## 8. Contract Award

(a) The PHA/IHA will evaluate bids in response to this solicitation without discussions and will award a contract to the responsible bidder whose bid, conforming to the solicitation, will be most advantageous to the PHA/IHA considering only price and any price-related factors specified in the solicitation.

(b) If the apparent low bid received in response to this solicitation exceeds the PHA's/IHA's available funding for the proposed contract work, the PHA/IHA may either accept separately priced items (see 8(e) below) or use the following procedure to determine contract award. The PHA/IHA shall apply in turn to each bid (proceeding in order from the apparent low bid to the high bid) each of the separately priced bid deductible items, if any, in their priority order set forth in this solicitation. If upon the application of the first deductible item to all initial bids, a new low bid is within the PHA's/IHA's available funding, then award shall be made to that bidder. If no bid is within the available funding amount, then the PHA/IHA shall apply the second deductible item. The PHA/IHA shall continue this process until an evaluated low bid, if any, is within the PHA's/IHA's available funding. If upon the application of all deductibles, no bid is within the PHA's/IHA's available funding, or if the solicitation does not request separately priced deductibles, the PHA/IHA shall follow its written policy and procedures in making any award under this solicitation.

(c) In the case of tie low bids, award shall be made in accordance with the PHA's/IHA's written policy and procedures.

(d) The PHA/IHA may reject any and all bids, except other than the lowest bid (e.g., the apparent low bid is unreasonably low), and waive informalities or minor irregularities in bids received, in accordance with the PHA's/IHA's written policy and procedures.

(e) Unless precluded elsewhere in the solicitation, the PHA/IHA may accept any item or combination of items bid.

(f) The PHA/IHA may reject any bid as nonresponsive if it is materially unbalanced as to the prices for the various items of work to be performed. A bid is materially unbalanced when it is based on prices significantly less than cost for some work and prices which are significantly overstated for other work.

(g) A written award shall be furnished to the successful bidder within the period for acceptance specified in the bid and shall result in a binding contract without further action by either party.

**9. Bid Guarantee (applicable to construction and equipment contracts exceeding \$25,000)**

All bids must be accompanied by a negotiable bid guarantee which shall not be less than five percent (5%) of the amount of the bid. The bid guarantee may be a certified check, bank draft, U.S. Government Bonds at par value, or a bid bond secured by a surety company acceptable to the U.S. Government and authorized to do business in the state where the work is to be performed. In the case where the work under the contract will be performed on an Indian reservation area, the bid guarantee may also be an irrevocable Letter of Credit (see provision 10, Assurance of Completion, below). Certified checks and bank drafts must be made payable to the order of the PHA/IHA. The bid guarantee shall insure the execution of the contract and the furnishing of a method of assurance of completion by the successful bidder as required by the solicitation. Failure to submit a bid guarantee with the bid shall result in the rejection of the bid. Bid guarantees submitted by unsuccessful bidders will be returned as soon as practicable after bid opening.

**10. Assurance of Completion**

(a) Unless otherwise provided in State law, the successful bidder shall furnish an assurance of completion prior to the execution of any contract under this solicitation. This assurance may be [Contracting Officer check applicable items] —

[ ] (1) a performance and payment bond in a penal sum of 100 percent of the contract price; or, as may be required or permitted by State law;

[ ] (2) separate performance and payment bonds, each for 50 percent or more of the contract price;

[ ] (3) a 20 percent cash escrow;

[ ] (4) a 25 percent irrevocable letter of credit; or,

[ ] (5) an irrevocable letter of credit for 10 percent of the total contract price with a monitoring and disbursements agreement with the IHA (applicable only to contracts awarded by an IHA under the Indian Housing Program).

(b) Bonds must be obtained from guarantee or surety companies acceptable to the U.S. Government and authorized to do business in the state where the work is to be performed. Individual sureties will not be considered. U.S. Treasury Circular Number 570, published annually in the Federal Register, lists companies approved to act as sureties on bonds securing Government contracts, the maximum underwriting limits on each contract bonded, and the States in which the company is licensed to do business. Use of companies listed in this circular is mandatory. Copies of the circular may be downloaded on the U.S. Department of Treasury website <http://www.fms.treas.gov/c570/index.html>, or ordered for a minimum fee by contacting the Government Printing Office at (202) 512-2168.

(c) Each bond shall clearly state the rate of premium and the total amount of premium charged. The current power of attorney for the person who signs for the surety company must be attached to the bond. The effective date of the power of attorney shall not precede the date of the bond. The effective date of the bond shall be on or after the execution date of the contract.

(d) Failure by the successful bidder to obtain the required assurance of completion within the time specified, or within such extended period as the PHA/IHA may grant based upon reasons determined adequate by the PHA/IHA, shall render the bidder ineligible for award. The PHA/IHA may then either award the contract to the next lowest responsible bidder or solicit new bids. The PHA/IHA may retain the ineligible bidder's bid guarantee.

**11. Preconstruction Conference (applicable to construction contracts)**

After award of a contract under this solicitation and prior to the start of work, the successful bidder will be required to attend a preconstruction conference with representatives of the PHA/IHA and its architect/engineer, and other interested parties convened by the PHA/IHA. The conference will serve to acquaint the participants with the general plan of the construction operation and all other requirements of the contract (e.g., Equal Employment Opportunity, Labor Standards). The PHA/IHA will provide the successful bidder with the date, time, and place of the conference.

**12. Indian Preference Requirements (applicable only if this solicitation is for a contract to be performed on a project for an Indian Housing Authority)**

(a) HUD has determined that the contract awarded under this solicitation is subject to the requirements of section 7(b) of the Indian Self-Determination and Education Assistance Act (25 U.S.C. 450e(b)). Section 7(b) requires that any contract or subcontract entered into for the benefit of Indians shall require that, to the greatest extent feasible

(1) Preferences and opportunities for training and employment (other than core crew positions; see paragraph (h) below) in connection with the administration of such contracts or subcontracts be given to qualified "Indians." The Act defines "Indians" to mean persons who are members of an Indian tribe and defines "Indian tribe" to mean any Indian tribe, band, nation, or other organized group or community, including any Alaska Native village or regional or village corporation as defined in or established pursuant to the Alaska Native Claims Settlement Act, which is recognized as eligible for the special programs and services provided by the United States to Indians because of their status as Indians; and,

(2) Preference in the award of contracts or subcontracts in connection with the administration of contracts be given to Indian organizations and to Indian-owned economic enterprises, as defined in section 3 of the Indian Financing Act of 1974 (25 U.S.C. 1452). That Act defines "economic enterprise" to mean any Indian-owned commercial, industrial, or business activity established or organized for the purpose of profit, except that the Indian ownership must constitute not less than 51 percent of the enterprise; "Indian organization" to mean the governing body of any Indian tribe or entity established or recognized by such governing body; "Indian" to mean any person who is a member of any tribe, band, group, pueblo, or community which is recognized by the Federal Government as eligible for services from the Bureau of Indian Affairs and any "Native" as defined in the Alaska Native Claims Settlement Act; and Indian "tribe" to mean any Indian tribe, band, group, pueblo, or community including Native villages and Native groups (including

corporations organized by Kenai, Juneau, Sitka, and Kodiak) as defined in the Alaska Native Claims Settlement Act, which is recognized by the Federal Government as eligible for services from the Bureau of Indian Affairs.

(b) (1) The successful Contractor under this solicitation shall comply with the requirements of this provision in awarding all subcontracts under the contract and in providing training and employment opportunities.

(2) A finding by the IHA that the contractor, either (i) awarded a subcontract without using the procedure required by the IHA, (ii) falsely represented that subcontracts would be awarded to Indian enterprises or organizations; or, (iii) failed to comply with the contractor's employment and training preference bid statement shall be grounds for termination of the contract or for the assessment of penalties or other remedies.

(c) If specified elsewhere in this solicitation, the IHA may restrict the solicitation to qualified Indian-owned enterprises and Indian organizations. If two or more (or a greater number as specified elsewhere in the solicitation) qualified Indian-owned enterprises or organizations submit responsive bids, award shall be made to the qualified enterprise or organization with the lowest responsive bid. If fewer than the minimum required number of qualified Indian-owned enterprises or organizations submit responsive bids, the IHA shall reject all bids and readvertise the solicitation in accordance with paragraph (d) below.

(d) If the IHA prefers not to restrict the solicitation as described in paragraph (c) above, or if after having restricted a solicitation an insufficient number of qualified Indian enterprises or organizations submit bids, the IHA may advertise for bids from non-Indian as well as Indian-owned enterprises and Indian organizations. Award shall be made to the qualified Indian enterprise or organization with the lowest responsive bid if that bid is -

(1) Within the maximum HUD-approved budget amount established for the specific project or activity for which bids are being solicited; and

(2) No more than the percentage specified in 24 CFR 905.175(c) higher than the total bid price of the lowest responsive bid from any qualified bidder. If no responsive bid by a qualified Indian-owned economic enterprise or organization is within the stated range of the total bid price of the lowest responsive bid from any qualified enterprise, award shall be made to the bidder with the lowest bid.

(e) Bidders seeking to qualify for preference in contracting or subcontracting shall submit proof of Indian ownership with their bids. Proof of Indian ownership shall include but not be limited to:

(1) Certification by a tribe or other evidence that the bidder is an Indian. The IHA shall accept the certification of a tribe that an individual is a member.

(2) Evidence such as stock ownership, structure, management, control, financing and salary or profit sharing arrangements of the enterprise.

(f) (1) All bidders must submit with their bids a statement describing how they will provide Indian preference in the award of subcontracts. The specific requirements of that statement and the factors to be used by the IHA in determining the statement's adequacy are included as an attachment to this solicitation. Any bid that fails to include the required statement shall be rejected as nonresponsive. The IHA may require that comparable statements be provided by subcontractors to the successful Contractor, and may require the Contractor to reject any bid or proposal by a subcontractor that fails to include the statement.

(2) Bidders and prospective subcontractors shall submit a certification (supported by credible evidence) to the IHA in any instance where the bidder or subcontractor believes it is infeasible to provide Indian preference in subcontracting. The acceptance or rejection by the IHA of the certification shall be final. Rejection shall disqualify the bid from further consideration.

(g) All bidders must submit with their bids a statement detailing their employment and training opportunities and their plans to provide preference to Indians in implementing the contract; and the number or percentage of Indians anticipated to be employed and trained. Comparable statements from all proposed subcontractors must be submitted. The criteria to be used by the IHA in determining the statement(s)'s adequacy are included as an attachment to this solicitation. Any bid that fails to include the required statement(s), or that includes a statement that does not meet minimum standards required by the IHA shall be rejected as nonresponsive.

(h) Core crew employees. A core crew employee is an individual who is a bona fide employee of the contractor at the time the bid is submitted; or an individual who was not employed by the bidder at the time the bid was submitted, but who is regularly employed by the bidder in a supervisory or other key skilled position when work is available. Bidders shall submit with their bids a list of all core crew employees.

(i) Preference in contracting, subcontracting, employment, and training shall apply not only on-site, on the reservation, or within the IHA's jurisdiction, but also to contracts with firms that operate outside these areas (e.g., employment in modular or manufactured housing construction facilities).

(j) Bidders should contact the IHA to determine if any additional local preference requirements are applicable to this solicitation.

(k) The IHA [ ] does [ ] does not [Contracting Officer check applicable box] maintain lists of Indian-owned economic enterprises and Indian organizations by specialty (e.g., plumbing, electrical, foundations), which are available to bidders to assist them in meeting their responsibility to provide preference in connection with the administration of contracts and subcontracts.



**U.S. Department of Housing  
and Urban Development**  
Office of Public and Indian Housing

**Representations, Certifications,  
and Other Statements of Bidders**  
**Public and Indian Housing Programs**

# Representations, Certifications, and Other Statements of Bidders

## Public and Indian Housing Programs

### Table of Contents

Clause	Page
1. Certificate of Independent Price Determination	1
2. Contingent Fee Representation and Agreement	1
3. Certification and Disclosure Regarding Payments to Influence Certain Federal Transactions	1
4. Organizational Conflicts of Interest Certification	2
5. Bidder's Certification of Eligibility	2
6. Minimum Bid Acceptance Period	2
7. Small, Minority, Women-Owned Business Concern Representation	2
8. Indian-Owned Economic Enterprise and Indian Organization Representation	2
9. Certification of Eligibility Under the Davis-Bacon Act	3
10. Certification of Nonsegregated Facilities	3
11. Clean Air and Water Certification	3
12. Previous Participation Certificate	3
13. Bidder's Signature	3

### 1. Certificate of Independent Price Determination

(a) The bidder certifies that--

(1) The prices in this bid have been arrived at independently, without, for the purpose of restricting competition, any consultation, communication, or agreement with any other bidder or competitor relating to (i) those prices, (ii) the intention to submit a bid, or (iii) the methods or factors used to calculate the prices offered;

(2) The prices in this bid have not been and will not be knowingly disclosed by the bidder, directly or indirectly, to any other bidder or competitor before bid opening (in the case of a sealed bid solicitation) or contract award (in the case of a competitive proposal solicitation) unless otherwise required by law; and

(3) No attempt has been made or will be made by the bidder to induce any other concern to submit or not to submit a bid for the purpose of restricting competition.

(b) Each signature on the bid is considered to be a certification by the signatory that the signatory--

(1) Is the person in the bidder's organization responsible for determining the prices being offered in this bid or proposal, and that the signatory has not participated and will not participate in any action contrary to subparagraphs (a)(1) through (a)(3) above; or

(2) (i) Has been authorized, in writing, to act as agent for the following principals in certifying that those principals have not participated, and will not participate in any action contrary to subparagraphs (a)(1) through (a)(3) above.

\_\_\_\_\_ [insert full name of person(s) in the bidder's organization responsible for determining the prices offered in this bid or proposal, and the title of his or her position in the bidder's organization];

(ii) As an authorized agent, does certify that the principals named in subdivision (b)(2)(i) above have not participated, and will not participate, in any action contrary to subparagraphs (a)(1) through (a)(3) above; and

(iii) As an agent, has not personally participated, and will not participate in any action contrary to subparagraphs (a)(1) through (a)(3) above.

(c) If the bidder deletes or modifies subparagraph (a)2 above, the bidder must furnish with its bid a signed statement setting forth in detail the circumstances of the disclosure.

[ ] [Contracting Officer check if following paragraph is applicable]

(d) Non-collusive affidavit. (applicable to contracts for construction and equipment exceeding \$50,000)

(1) Each bidder shall execute, in the form provided by the PHA/IHA, an affidavit to the effect that he/she has not colluded with any other person, firm or corporation in regard to any bid submitted in response to this solicitation. If the successful bidder did not submit the affidavit with his/her bid, he/she must submit it within three (3) working days of bid opening. Failure to submit the affidavit by that date may render the bid nonresponsive. No contract award will be made without a properly executed affidavit.

(2) A fully executed "Non-collusive Affidavit" [ ] is, [ ] is not included with the bid.

### 2. Contingent Fee Representation and Agreement

(a) Definitions. As used in this provision:

"Bona fide employee" means a person, employed by a bidder and subject to the bidder's supervision and control as to time, place, and manner of performance, who neither exerts, nor proposes to exert improper influence to solicit or obtain contracts nor holds out as being able to obtain any contract(s) through improper influence.

"Improper influence" means any influence that induces or tends to induce a PHA/IHA employee or officer to give consideration or to act regarding a PHA/IHA contract on any basis other than the merits of the matter.

(b) The bidder represents and certifies as part of its bid that, except for full-time bona fide employees working solely for the bidder, the bidder:

(1) [ ] has, [ ] has not employed or retained any person or company to solicit or obtain this contract; and

(2) [ ] has, [ ] has not paid or agreed to pay to any person or company employed or retained to solicit or obtain this contract any commission, percentage, brokerage, or other fee contingent upon or resulting from the award of this contract.

(c) If the answer to either (a)(1) or (a)(2) above is affirmative, the bidder shall make an immediate and full written disclosure to the PHA/IHA Contracting Officer.

(d) Any misrepresentation by the bidder shall give the PHA/IHA the right to (1) terminate the contract; (2) at its discretion, deduct from contract payments the amount of any commission, percentage, brokerage, or other contingent fee; or (3) take other remedy pursuant to the contract.

### 3. Certification and Disclosure Regarding Payments to Influence Certain Federal Transactions (applicable to contracts exceeding \$100,000)

(a) The definitions and prohibitions contained in Section 1352 of title 31, United States Code, are hereby incorporated by reference in paragraph (b) of this certification.

(b) The bidder, by signing its bid, hereby certifies to the best of his or her knowledge and belief as of December 23, 1989 that:

(1) No Federal appropriated funds have been paid or will be paid to any person for influencing or attempting to influence an officer or employee of any agency, a Member of Congress, an officer or employee of Congress, or an employee of a Member of Congress on his or her behalf in connection with the awarding of a contract resulting from this solicitation;

(2) If any funds other than Federal appropriated funds (including profit or fee received under a covered Federal transaction) have been paid, or will be paid, to any person for influencing or attempting to influence an officer or employee of any agency, a Member of Congress, an officer or employee of Congress, or an employee of a Member of Congress on his or her behalf in connection with this solicitation, the bidder shall complete and submit, with its bid, OMB standard form LLL, "Disclosure of Lobbying Activities;" and

(3) He or she will include the language of this certification in all subcontracts at any tier and require that all recipients of subcontract awards in excess of \$100,000 shall certify and disclose accordingly.

(c) Submission of this certification and disclosure is a prerequisite for making or entering into this contract imposed by section 1352, title 31, United States Code. Any person who makes an expenditure prohibited under this provision or who fails to file or amend the disclosure form to be filed or amended by this provision, shall be subject to a civil penalty of not less than \$10,000, and not more than \$100,000, for each such failure.

(d) Indian tribes (except those chartered by States) and Indian organizations as defined in section 4 of the Indian Self-Determination and Education Assistance Act (25 U.S.C. 450B) are exempt from the requirements of this provision.

#### 4. Organizational Conflicts of Interest Certification

The bidder certifies that to the best of its knowledge and belief and except as otherwise disclosed, he or she does not have any organizational conflict of interest which is defined as a situation in which the nature of work to be performed under this proposed contract and the bidder's organizational, financial, contractual, or other interests may, without some restriction on future activities:

- (a) Result in an unfair competitive advantage to the bidder; or,
  - (b) Impair the bidder's objectivity in performing the contract work.
- In the absence of any actual or apparent conflict, I hereby certify that to the best of my knowledge and belief, no actual or apparent conflict of interest exists with regard to my possible performance of this procurement.

#### 5. Bidder's Certification of Eligibility

(a) By the submission of this bid, the bidder certifies that to the best of its knowledge and belief, neither it, nor any person or firm which has an interest in the bidder's firm, nor any of the bidder's subcontractors, is ineligible to:

(1) Be awarded contracts by any agency of the United States Government, HUD, or the State in which this contract is to be performed; or,

(2) Participate in HUD programs pursuant to 24 CFR Part 24.

(b) The certification in paragraph (a) above is a material representation of fact upon which reliance was placed when making award. If it is later determined that the bidder knowingly rendered an erroneous certification, the contract may be terminated for default, and the bidder may be debarred or suspended from participation in HUD programs and other Federal contract programs.

#### 6. Minimum Bid Acceptance Period

(a) "Acceptance period," as used in this provision, means the number of calendar days available to the PHA/IHA for awarding a contract from the date specified in this solicitation for receipt of bids.

(b) This provision supersedes any language pertaining to the acceptance period that may appear elsewhere in this solicitation.

(c) The PHA/IHA requires a minimum acceptance period of [Contracting Officer insert time period] calendar days.

(d) In the space provided immediately below, bidders may specify a longer acceptance period than the PHA's/IHA's minimum requirement. The bidder allows the following acceptance period: calendar days.

(e) A bid allowing less than the PHA's/IHA's minimum acceptance period will be rejected.

(f) The bidder agrees to execute all that it has undertaken to do, in compliance with its bid, if that bid is accepted in writing within (1) the acceptance period stated in paragraph (c) above or (2) any longer acceptance period stated in paragraph (d) above.

#### 7. Small, Minority, Women-Owned Business Concern Representation

The bidder represents and certifies as part of its bid/ offer that it --

(a)  is,  is not a small business concern. "Small business concern," as used in this provision, means a concern, including its affiliates, that is independently owned and operated, not dominant in the field of operation in which it is bidding, and qualified as a small business under the criteria and size standards in 13 CFR 121.

(b)  is,  is not a women-owned business enterprise. "Women-owned business enterprise," as used in this provision, means a business that is at least 51 percent owned by a woman or women who are U.S. citizens and who also control and operate the business.

(c)  is,  is not a minority business enterprise. "Minority business enterprise," as used in this provision, means a business which is at least 51 percent owned or controlled by one or more minority group members or, in the case of a publicly owned business, at least 51 percent of its voting stock is owned by one or more minority group members, and whose management and daily operations are controlled by one or more such individuals. For the purpose of this definition, minority group members are:

(Check the block applicable to you)

- |   |   |
|---|---|
| <input type="checkbox"/> Black Americans    | <input type="checkbox"/> Asian Pacific Americans  |
| <input type="checkbox"/> Hispanic Americans | <input type="checkbox"/> Asian Indian Americans   |
| <input type="checkbox"/> Native Americans   | <input type="checkbox"/> Hasidic Jewish Americans |

#### 8. Indian-Owned Economic Enterprise and Indian Organization Representation (applicable only if this solicitation is for a contract to be performed on a project for an Indian Housing Authority)

The bidder represents and certifies that it:

(a)  is,  is not an Indian-owned economic enterprise. "Economic enterprise," as used in this provision, means any commercial, industrial, or business activity established or organized for the purpose of profit, which is at least 51 percent Indian owned. "Indian," as used in this provision, means any person who is a member of any tribe, band, group, pueblo, or community which is recognized by the Federal Government as eligible for services from the Bureau of Indian Affairs and any "Native" as defined in the Alaska Native Claims Settlement Act.

(b)  is,  is not an Indian organization. "Indian organization," as used in this provision, means the governing body of any Indian tribe or entity established or recognized by such governing body. Indian "tribe" means any Indian tribe, band, group, pueblo, or

community including Native villages and Native groups (including corporations organized by Kenai, Juneau, Sitka, and Kodiak) as defined in the Alaska Native Claims Settlement Act, which is recognized by the Federal Government as eligible for services from the Bureau of Indian Affairs.

**9. Certification of Eligibility Under the Davis-Bacon Act** (applicable to construction contracts exceeding \$2,000)

(a) By the submission of this bid, the bidder certifies that neither it nor any person or firm who has an interest in the bidder's firm is a person or firm ineligible to be awarded contracts by the United States Government by virtue of section 3(a) of the Davis-Bacon Act or 29 CFR 5.12(a)(1).

(b) No part of the contract resulting from this solicitation shall be subcontracted to any person or firm ineligible to be awarded contracts by the United States Government by virtue of section 3(a) of the Davis-Bacon Act or 29 CFR 5.12(a)(1).

(c) The penalty for making false statements is prescribed in the U. S. Criminal Code, 18 U.S.C. 1001.

**10. Certification of Nonsegregated Facilities** (applicable to contracts exceeding \$10,000)

(a) The bidder's attention is called to the clause entitled **Equal Employment Opportunity** of the General Conditions of the Contract for Construction.

(b) "Segregated facilities," as used in this provision, means any waiting rooms, work areas, rest rooms and wash rooms, restaurants and other eating areas, time clocks, locker rooms and other storage or dressing areas, parking lots, drinking fountains, recreation or entertainment areas, transportation, and housing facilities provided for employees, that are segregated by explicit directive or are in fact segregated on the basis of race, color, religion, or national origin because of habit, local custom, or otherwise.

(c) By the submission of this bid, the bidder certifies that it does not and will not maintain or provide for its employees any segregated facilities at any of its establishments, and that it does not and will not permit its employees to perform their services at any location under its control where segregated facilities are maintained. The bidder agrees that a breach of this certification is a violation of the Equal Employment Opportunity clause in the contract.

(d) The bidder further agrees that (except where it has obtained identical certifications from proposed subcontractors for specific time periods) prior to entering into subcontracts which exceed \$10,000 and are not exempt from the requirements of the Equal Employment Opportunity clause, it will:

(1) Obtain identical certifications from the proposed subcontractors;

(2) Retain the certifications in its files; and

(3) Forward the following notice to the proposed subcontractors (except if the proposed subcontractors have submitted identical certifications for specific time periods):

**Notice to Prospective Subcontractors of Requirement for Certifications of Nonsegregated Facilities**

A Certification of Nonsegregated Facilities must be submitted before the award of a subcontract exceeding \$10,000 which is not exempt from the provisions of the Equal Employment Opportunity clause of the prime contract. The certification may be submitted either for each subcontract or for all subcontracts during a period (i.e., quarterly, semiannually, or annually).

**Note:** The penalty for making false statements in bids is prescribed in 18 U.S.C. 1001.

**11. Clean Air and Water Certification** (applicable to contracts exceeding \$100,000)

The bidder certifies that:

(a) Any facility to be used in the performance of this contract [ ] is, [ ] is not listed on the Environmental Protection Agency List of Violating Facilities:

(b) The bidder will immediately notify the PHA/IHA Contracting Officer, before award, of the receipt of any communication from the Administrator, or a designee, of the Environmental Protection Agency, indicating that any facility that the bidder proposes to use for the performance of the contract is under consideration to be listed on the EPA List of Violating Facilities; and,

(c) The bidder will include a certification substantially the same as this certification, including this paragraph (c), in every nonexempt subcontract.

**12. Previous Participation Certificate** (applicable to construction and equipment contracts exceeding \$50,000)

(a) The bidder shall complete and submit with his/her bid the Form HUD-2530, "Previous Participation Certificate." If the successful bidder does not submit the certificate with his/her bid, he/she must submit it within three (3) working days of bid opening. Failure to submit the certificate by that date may render the bid nonresponsive. No contract award will be made without a properly executed certificate.

(b) A fully executed "Previous Participation Certificate" [ ] is, [ ] is not included with the bid.

**13. Bidder's Signature**

The bidder hereby certifies that the information contained in these certifications and representations is accurate, complete, and current.

\_\_\_\_\_  
(Signature and Date)

\_\_\_\_\_  
(Typed or Printed Name)

\_\_\_\_\_  
(Title)

\_\_\_\_\_  
(Company Name)

\_\_\_\_\_  
(Company Address)

# General Conditions for Construction Contracts - Public Housing Programs

U.S. Department of Housing and Urban Development  
Office of Public and Indian Housing  
OMB Approval No. 2577-0157 (exp. 3/31/2020)

**Applicability. This form is applicable to any construction/development contract greater than \$150,000.**

This form includes those clauses required by OMB's common rule on grantee procurement, implemented at HUD in 2 CFR 200, and those requirements set forth in Section 3 of the Housing and Urban Development Act of 1968 and its amendment by the Housing and Community Development Act of 1992, implemented by HUD at 24 CFR Part 135. The form is required for construction contracts awarded by Public Housing Agencies (PHAs).

The form is used by Housing Authorities in solicitations to provide necessary contract clauses. If the form were not used, HAs would be unable to enforce their contracts.

Public reporting burden for this collection of information is estimated to average 1.0 hours per response, including the time for reviewing instructions, searching existing data sources, gathering and maintaining the data needed, and completing and reviewing the collection of information. Responses to the collection of information are required to obtain a benefit or to retain a benefit.

The information requested does not lend itself to confidentiality.

HUD may not conduct or sponsor, and a person is not required to respond to a collection of information unless it displays a currently valid OMB number.

Clause		Page	Clause		Page
1.	Definitions	2	<b>Administrative Requirements</b>		
2.	Contractor's Responsibility for Work	2	25.	Contract Period	9
3.	Architect's Duties, Responsibilities and Authority	2	26.	Order of Precedence	9
4.	Other Contracts	3	27.	Payments	9
<b>Construction Requirements</b>			28.	Contract Modifications	10
5.	Preconstruction Conference and Notice to Proceed	3	29.	Changes	10
6.	Construction Progress Schedule	3	30.	Suspension of Work	11
7.	Site Investigation and Conditions Affecting the Work	3	31.	Disputes	11
8.	Differing Site Conditions	4	32.	Default	11
9.	Specifications and Drawings for Construction	4	33.	Liquidated	12
10.	As-Built Drawings	5	34.	Termination of Convenience	12
11.	Material and Workmanship	5	35.	Assignment of Contract	12
12.	Permits and Codes	5	36.	Insurance	12
13.	Health, Safety, and Accident Prevention	6	37.	Subcontracts	13
14.	Temporary Buildings and Transportation Materials	6	38.	Subcontracting with Small and Minority Firms, Women's Business Enterprise, and Labor Surplus Area Firms	13
15.	Availability and Use of Utility Services	6	39.	Equal Employment Opportunity	13
16.	Protection of Existing Vegetation, Structures, Equipment, Utilities, and Improvements	6	40.	Employment, Training, and Contracting Opportunities for Low-Income Persons, Section 3 of the Housing and Urban Development Act of 1968	14
17.	Temporary Buildings and Transportation Materials	7	41.	Interest of Members of Congress	15
18.	Clean Air and Water	7	42.	Interest of Members, Officers, or Employees and Former Members, Officers, or Employees	15
19.	Energy Efficiency	7	43.	Limitations on Payments Made to Influence	15
20.	Inspection and Acceptance of Construction	7	44.	Royalties and Patents	15
21.	Use and Possession Prior to	8	45.	Examination and Retention of Contractor's Records	15
22.	Warranty of Title	8	46.	Labor Standards-Davis-Bacon and Related Acts	15
23.	Warranty of	8	47.	Non-Federal Prevailing Wage Rates	19
24.	Prohibition Against	9	48.	Procurement of Recovered	19

---

## 1. Definitions

- (a) "Architect" means the person or other entity engaged by the PHA to perform architectural, engineering, design, and other services related to the work as provided for in the contract. When a PHA uses an engineer to act in this capacity, the terms "architect" and "engineer" shall be synonymous. The Architect shall serve as a technical representative of the Contracting Officer. The Architect's authority is as set forth elsewhere in this contract.
  - (b) "Contract" means the contract entered into between the PHA and the Contractor. It includes the forms of Bid, the Bid Bond, the Performance and Payment Bond or Bonds or other assurance of completion, the Certifications, Representations, and Other Statements of Bidders (form HUD-5370), these General Conditions of the Contract for Construction (form HUD-5370), the applicable wage rate determinations from the U.S. Department of Labor, any special conditions included elsewhere in the contract, the specifications, and drawings. It includes all formal changes to any of those documents by addendum, change order, or other modification.
  - (c) "Contracting Officer" means the person delegated the authority by the PHA to enter into, administer, and/or terminate this contract and designated as such in writing to the Contractor. The term includes any successor Contracting Officer and any duly authorized representative of the Contracting Officer also designated in writing. The Contracting Officer shall be deemed the authorized agent of the PHA in all dealings with the Contractor.
  - (d) "Contractor" means the person or other entity entering into the contract with the PHA to perform all of the work required under the contract.
  - (e) "Drawings" means the drawings enumerated in the schedule of drawings contained in the Specifications and as described in the contract clause entitled Specifications and Drawings for Construction herein.
  - (f) "HUD" means the United States of America acting through the Department of Housing and Urban Development including the Secretary, or any other person designated to act on its behalf. HUD has agreed, subject to the provisions of an Annual Contributions Contract (ACC), to provide financial assistance to the PHA, which includes assistance in financing the work to be performed under this contract. As defined elsewhere in these General Conditions or the contract documents, the determination of HUD may be required to authorize changes in the work or for release of funds to the PHA for payment to the Contractor. Notwithstanding HUD's role, nothing in this contract shall be construed to create any contractual relationship between the Contractor and HUD.
  - (g) "Project" means the entire project, whether construction or rehabilitation, the work for which is provided for in whole or in part under this contract.
  - (h) "PHA" means the Public Housing Agency organized under applicable state laws which is a party to this contract.
  - (j) "Specifications" means the written description of the technical requirements for construction and includes the criteria and tests for determining whether the requirements are met.
  - (l) "Work" means materials, workmanship, and manufacture and fabrication of components.
- (a) The Contractor shall furnish all necessary labor, materials, tools, equipment, and transportation necessary for performance of the work. The Contractor shall also furnish all necessary water, heat, light, and power not made available to the Contractor by the PHA pursuant to the clause entitled Availability and Use of Utility Services herein.
  - (b) The Contractor shall perform on the site, and with its own organization, work equivalent to at least [ ] (12 percent unless otherwise indicated) of the total amount of work to be performed under the order. This percentage may be reduced by a supplemental agreement to this order if, during performing the work, the Contractor requests a reduction and the Contracting Officer determines that the reduction would be to the advantage of the PHA.
  - (c) At all times during performance of this contract and until the work is completed and accepted, the Contractor shall directly superintend the work or assign and have on the work site a competent superintendent who is satisfactory to the Contracting Officer and has authority to act for the Contractor.
  - (d) The Contractor shall be responsible for all damages to persons or property that occur as a result of the Contractor's fault or negligence, and shall take proper safety and health precautions to protect the work, the workers, the public, and the property of others. The Contractor shall hold and save the PHA, its officers and agents, free and harmless from liability of any nature occasioned by the Contractor's performance. The Contractor shall also be responsible for all materials delivered and work performed until completion and acceptance of the entire work, except for any completed unit of work which may have been accepted under the contract.
  - (e) The Contractor shall lay out the work from base lines and bench marks indicated on the drawings and be responsible for all lines, levels, and measurements of all work executed under the contract. The Contractor shall verify the figures before laying out the work and will be held responsible for any error resulting from its failure to do so.
  - (f) The Contractor shall confine all operations (including storage of materials) on PHA premises to areas authorized or approved by the Contracting Officer.
  - (g) The Contractor shall at all times keep the work area, including storage areas, free from accumulations of waste materials. After completing the work and before final inspection, the Contractor shall (1) remove from the premises all scaffolding, equipment, tools, and materials (including rejected materials) that are not the property of the PHA and all rubbish caused by its work; (2) leave the work area in a clean, neat, and orderly condition satisfactory to the Contracting Officer; (3) perform all specified tests; and, (4) deliver the installation in complete and operating condition.
  - (h) The Contractor's responsibility will terminate when all work has been completed, the final inspection made, and the work accepted by the Contracting Officer. The Contractor will then be released from further obligation except as required by the warranties specified elsewhere in the contract.

## 3. Architect's Duties, Responsibilities, and Authority

- (a) The Architect for this contract, and any successor, shall be designated in writing by the Contracting Officer.

## 2. Contractor's Responsibility for Work



- 
- (b) The Architect shall serve as the Contracting Officer's technical representative with respect to architectural, engineering, and design matters related to the work performed under the contract. The Architect may provide direction on contract performance. Such direction shall be within the scope of the contract and may not be of a nature which: (1) institutes additional work outside the scope of the contract; (2) constitutes a change as defined in the Changes clause herein; (3) causes an increase or decrease in the cost of the contract; (4) alters the Construction Progress Schedule; or (5) changes any of the other express terms or conditions of the contract.
- (c) The Architect's duties and responsibilities may include but shall not be limited to:
- (1) Making periodic visits to the work site, and on the basis of his/her on-site inspections, issuing written reports to the PHA which shall include all observed deficiencies. The Architect shall file a copy of the report with the Contractor's designated representative at the site;
  - (2) Making modifications in drawings and technical specifications and assisting the Contracting Officer in the preparation of change orders and other contract modifications for issuance by the Contracting Officer;
  - (3) Reviewing and making recommendations with respect to - (i) the Contractor's construction progress schedules; (ii) the Contractor's shop and detailed drawings; (iii) the machinery, mechanical and other equipment and materials or other articles proposed for use by the Contractor; and, (iv) the Contractor's price breakdown and progress payment estimates; and,
  - (4) Assisting in inspections, signing Certificates of Completion, and making recommendations with respect to acceptance of work completed under the contract.

#### 4. Other Contracts

The PHA may undertake or award other contracts for additional work at or near the site of the work under this contract. The Contractor shall fully cooperate with the other contractors and with PHA employees and shall carefully adapt scheduling and performing the work under this contract to accommodate the additional work, heeding any direction that may be provided by the Contracting Officer. The Contractor shall not commit or permit any act that will interfere with the performance of work by any other contractor or by PHA employees

### Construction Requirements

#### 5. Pre-construction Conference and Notice to Proceed

- (a) Within ten calendar days of contract execution, and prior to the commencement of work, the Contractor shall attend a preconstruction conference with representatives of the PHA, its Architect, and other interested parties convened by the PHA. The conference will serve to acquaint the participants with the general plan of the construction operation and all other requirements of the contract. The PHA will provide the Contractor with the date, time, and place of the conference.
- (b) The contractor shall begin work upon receipt of a written Notice to Proceed from the Contracting Officer or designee. The Contractor shall not begin work prior to receiving such notice.

#### 6. Construction Progress Schedule

- (a) The Contractor shall, within five days after the work commences on the contract or another period of time determined by the Contracting Officer, prepare and submit to the Contracting Officer for approval three copies of a practicable schedule showing the order in which the Contractor proposes to perform the work, and the dates on which the Contractor contemplates starting and completing the several salient features of the work (including acquiring labor, materials, and equipment). The schedule shall be in the form of a progress chart of suitable scale to indicate appropriately the percentage of work scheduled for completion by any given date during the period. If the Contractor fails to submit a schedule within the time prescribed, the Contracting Officer may withhold approval of progress payments or take other remedies under the contract until the Contractor submits the required schedule.
- (b) The Contractor shall enter the actual progress on the chart as required by the Contracting Officer, and immediately deliver three copies of the annotated schedule to the Contracting Officer. If the Contracting Officer determines, upon the basis of inspection conducted pursuant to the clause entitled Inspection and Acceptance of Construction, herein that the Contractor is not meeting the approved schedule, the Contractor shall take steps necessary to improve its progress, including those that may be required by the Contracting Officer, without additional cost to the PHA. In this circumstance, the Contracting Officer may require the Contractor to increase the number of shifts, overtime operations, days of work, and/or the amount of construction plant, and to submit for approval any supplementary schedule or schedules in chart form as the Contracting Officer deems necessary to demonstrate how the approved rate of progress will be regained.
- (c) Failure of the Contractor to comply with the requirements of the Contracting Officer under this clause shall be grounds for a determination by the Contracting Officer that the Contractor is not prosecuting the work with sufficient diligence to ensure completion within the time specified in the Contract. Upon making this determination, the Contracting Officer may terminate the Contractor's right to proceed with the work, or any separable part of it, in accordance with the Default clause of this contract.

#### 7. Site Investigation and Conditions Affecting the Work

- (a) The Contractor acknowledges that it has taken steps reasonably necessary to ascertain the nature and location of the work, and that it has investigated and satisfied itself as to the general and local conditions which can affect the work or its cost, including but not limited to, (1) conditions bearing upon transportation, disposal, handling, and storage of materials; (2) the availability of labor, water, electric power, and roads; (3) uncertainties of weather, river stages, tides, or similar physical conditions at the site; (4) the conformation and conditions of the ground; and (5) the character of equipment and facilities needed preliminary to and during work performance. The Contractor also acknowledges that it has satisfied itself as to the character, quality, and quantity of surface and subsurface materials or obstacles to be encountered insofar as this information is

reasonably ascertainable from an inspection of the site, including all exploratory work done by the PHA, as well as from the drawings and specifications made a part of this contract. Any failure of the Contractor to take the actions described and acknowledged in this paragraph will not relieve the Contractor from responsibility for estimating properly the difficulty and cost of successfully performing the work, or for proceeding to successfully perform the work without additional expense to the PHA.

- (b) The PHA assumes no responsibility for any conclusions or interpretations made by the Contractor based on the information made available by the PHA. Nor does the PHA assume responsibility for any understanding reached or representation made concerning conditions which can affect the work by any of its officers or agents before the execution of this contract, unless that understanding or representation is expressly stated in this contract.

### 8. Differing Site Conditions

- (a) The Contractor shall promptly, and before the conditions are disturbed, give a written notice to the Contracting Officer of (1) subsurface or latent physical conditions at the site which differ materially from those indicated in this contract, or (2) unknown physical conditions at the site(s), of an unusual nature, which differ materially from those ordinarily encountered and generally recognized as inhering in work of the character provided for in the contract.
- (b) The Contracting Officer shall investigate the site conditions promptly after receiving the notice. Work shall not proceed at the affected site, except at the Contractor's risk, until the Contracting Officer has provided written instructions to the Contractor. If the conditions do materially so differ and cause an increase or decrease in the Contractor's cost of, or the time required for, performing any part of the work under this contract, whether or not changed as a result of the conditions, the Contractor shall file a claim in writing to the PHA within ten days after receipt of such instructions and, in any event, before proceeding with the work. An equitable adjustment in the contract price, the delivery schedule, or both shall be made under this clause and the contract modified in writing accordingly.
- (c) No request by the Contractor for an equitable adjustment to the contract under this clause shall be allowed, unless the Contractor has given the written notice required; provided, that the time prescribed in (a) above for giving written notice may be extended by the Contracting Officer.
- (d) No request by the Contractor for an equitable adjustment to the contract for differing site conditions shall be allowed if made after final payment under this contract.

### 9. Specifications and Drawings for Construction

- (a) The Contractor shall keep on the work site a copy of the drawings and specifications and shall at all times give the Contracting Officer access thereto. Anything mentioned in the specifications and not shown on the drawings, or shown on the drawings and not mentioned in the specifications, shall be of like effect as if shown or mentioned in both. In case of difference between drawings and specifications, the specifications shall govern. In case of discrepancy in the figures, in the drawings, or in the specifications, the matter shall be

promptly submitted to the Contracting Officer, who shall promptly make a determination in writing. Any adjustment by the Contractor without such a determination shall be at its own risk and expense. The Contracting Officer shall furnish from time to time such detailed drawings and other information as considered necessary, unless otherwise provided.

- (b) Wherever in the specifications or upon the drawings the words "directed", "required", "ordered", "designated", "prescribed", or words of like import are used, it shall be understood that the "direction", "requirement", "order", "designation", or "prescription", or "the Contracting Officer is intended and similarly the words "approved", "acceptable", "satisfactory", or words of like import shall mean "approved by", or "acceptable to", or "satisfactory to" the Contracting Officer, unless otherwise expressly stated.
- (c) Where "as shown" "as indicated", "as detailed", or of similar import are used, it shall be understood that the reference is made to the drawings accompanying this contract unless stated otherwise. The word "provided" as used herein shall be understood to mean "provide complete in place" that is "furnished and installed".
- (d) "Shop drawings" means drawings, submitted to the PHA by the Contractor, subcontractor, or any lower tier subcontractor, showing in detail (1) the proposed fabrication and assembly of structural elements and (2) the installation (i.e., form, fit, and attachment details) of materials of equipment. It includes drawings, diagrams, layouts, schematics, descriptive literature, illustrations, schedules, performance and test data, and similar materials furnished by the Contractor to explain in detail specific portions of the work required by the contract. The PHA may duplicate, use, and disclose in any manner and for any purpose shop drawings delivered under this contract.
- (e) If this contract requires shop drawings, the Contractor shall coordinate all such drawings, and review them for accuracy, completeness, and compliance with other contract requirements and shall indicate its approval thereon as evidence of such coordination and review. Shop drawings submitted to the Contracting Officer without evidence of the Contractor's approval may be returned for resubmission. The Contracting Officer will indicate an approval or disapproval of the shop drawings and if not approved as submitted shall indicate the PHA's reasons therefore. Any work done before such approval shall be at the Contractor's risk. Approval by the Contracting Officer shall not relieve the Contractor from responsibility for any errors or omissions in such drawings, nor from responsibility for complying with the requirements of this contract, except with respect to variations described and approved in accordance with (f) below.
- (f) If shop drawings show variations from the contract requirements, the Contractor shall describe such variations in writing, separate from the drawings, at the time of submission. If the Architect approves any such variation and the Contracting Officer concurs, the Contracting Officer shall issue an appropriate modification to the contract, except that, if the variation is minor or does not involve a change in price or in time of performance, a modification need not be issued.
- (g) It shall be the responsibility of the Contractor to make timely requests of the PHA for such large scale and full size drawings, color schemes, and other additional information, not already in his possession, which shall be



---

required in the planning and production of the work. Such requests may be submitted as the need arises, but each such request shall be filed in ample time to permit appropriate action to be taken by all parties involved so as to avoid delay.

- (h) The Contractor shall submit to the Contracting Officer for approval four copies (unless otherwise indicated) of all shop drawings as called for under the various headings of these specifications. Three sets (unless otherwise indicated) of all shop drawings, will be retained by the PHA and one set will be returned to the Contractor. As required by the Contracting Officer, the Contractor, upon completing the work under this contract, shall furnish a complete set of all shop drawings as finally approved. These drawings shall show all changes and revisions made up to the time the work is completed and accepted.
- (i) This clause shall be included in all subcontracts at any tier. It shall be the responsibility of the Contractor to ensure that all shop drawings prepared by subcontractors are submitted to the Contracting Officer.

#### 10. As-Built Drawings

- (a) "As-built drawings," as used in this clause, means drawings submitted by the Contractor or subcontractor at any tier to show the construction of a particular structure or work as actually completed under the contract. "As-built drawings" shall be synonymous with "Record drawings."
- (b) As required by the Contracting Officer, the Contractor shall provide the Contracting Officer accurate information to be used in the preparation of permanent as-built drawings. For this purpose, the Contractor shall record on one set of contract drawings all changes from the installations originally indicated, and record final locations of underground lines by depth from finish grade and by accurate horizontal offset distances to permanent surface improvements such as buildings, curbs, or edges of walks.
- (c) This clause shall be included in all subcontracts at any tier. It shall be the responsibility of the Contractor to ensure that all as-built drawings prepared by subcontractors are submitted to the Contracting Officer.

#### 11. Material and Workmanship

- (a) All equipment, material, and articles furnished under this contract shall be new and of the most suitable grade for the purpose intended, unless otherwise specifically provided in this contract. References in the contract to equipment, material, articles, or patented processes by trade name, make, or catalog number, shall be regarded as establishing a standard of quality and shall not be construed as limiting competition. The Contractor may, at its option, use any equipment, material, article, or process that, in the judgment of, and as approved by the Contracting Officer, is equal to that named in the specifications, unless otherwise specifically provided in this contract.
- (b) Approval of equipment and materials.
  - (1) The Contractor shall obtain the Contracting Officer's approval of the machinery and mechanical and other equipment to be incorporated into the work. When requesting approval, the Contractor shall furnish to the Contracting Officer the name of the manufacturer, the model number, and other information concerning the performance, capacity, nature, and rating of the

machinery and mechanical and other equipment. When required by this contract or by the Contracting Officer, the Contractor shall also obtain the Contracting Officer's approval of the material or articles which the Contractor contemplates incorporating into the work. When requesting approval, the Contractor shall provide full information concerning the material or articles. Machinery, equipment, material, and articles that do not have the required approval shall be installed or used at the risk of subsequent rejection.

- (2) When required by the specifications or the Contracting Officer, the Contractor shall submit appropriately marked samples (and certificates related to them) for approval at the Contractor's expense, with all shipping charges prepaid. The Contractor shall label, or otherwise properly mark on the container, the material or product represented, its place of origin, the name of the producer, the Contractor's name, and the identification of the construction project for which the material or product is intended to be used.
- (3) Certificates shall be submitted in triplicate, describing each sample submitted for approval and certifying that the material, equipment or accessory complies with contract requirements. The certificates shall include the name and brand of the product, name of manufacturer, and the location where produced.
- (4) Approval of a sample shall not constitute a waiver of the PHA right to demand full compliance with contract requirements. Materials, equipment and accessories may be rejected for cause even though samples have been approved.
- (5) Wherever materials are required to comply with recognized standards or specifications, such specifications shall be accepted as establishing the technical qualities and testing methods, but shall not govern the number of tests required to be made nor modify other contract requirements. The Contracting Officer may require laboratory test reports on items submitted for approval or may approve materials on the basis of data submitted in certificates with samples. Check tests will be made on materials delivered for use only as frequently as the Contracting Officer determines necessary to insure compliance of materials with the specifications. The Contractor will assume all costs of retesting materials which fail to meet contract requirements and/or testing materials offered in substitution for those found deficient.
- (6) After approval, samples will be kept in the Project office until completion of work. They may be built into the work after a substantial quantity of the materials they represent has been built in and accepted.
- (c) Requirements concerning lead-based paint. The Contractor shall comply with the requirements concerning lead-based paint contained in the Lead-Based Paint Poisoning Prevention Act (42 U.S.C. 4821-4846) as implemented by 24 CFR Part 35.

#### 12. Permits and Codes

- (a) The Contractor shall give all notices and comply with all applicable laws, ordinances, codes, rules and regulations. Notwithstanding the requirement of the Contractor to comply with the drawings and specifications in the contract, all work installed shall comply with all applicable codes and regulations as amended by any

waivers. Before installing the work, the Contractor shall examine the drawings and the specifications for compliance with applicable codes and regulations bearing on the work and shall immediately report any discrepancy it may discover to the Contracting Officer. Where the requirements of the drawings and specifications fail to comply with the applicable code or regulation, the Contracting Officer shall modify the contract by change order pursuant to the clause entitled Changes herein to conform to the code or regulation.

- (b) The Contractor shall secure and pay for all permits, fees, and licenses necessary for the proper execution and completion of the work. Where the PHA can arrange for the issuance of all or part of these permits, fees and licenses, without cost to the Contractor, the contract amount shall be reduced accordingly.

### 13. Health, Safety, and Accident Prevention

- (a) In performing this contract, the Contractor shall:
  - (1) Ensure that no laborer or mechanic shall be required to work in surroundings or under working conditions which are unsanitary, hazardous, or dangerous to his/her health and/or safety as determined under construction safety and health standards promulgated by the Secretary of Labor by regulation;
  - (2) Protect the lives, health, and safety of other persons;
  - (3) Prevent damage to property, materials, supplies, and equipment; and,
  - (4) Avoid work interruptions.
- (b) For these purposes, the Contractor shall:
  - (1) Comply with regulations and standards issued by the Secretary of Labor at 29 CFR Part 1926. Failure to comply may result in imposition of sanctions pursuant to the Contract Work Hours and Safety Standards Act (Public Law 91-54, 83 Stat. 96), 40 U.S.C. 3701 et seq.; and
  - (2) Include the terms of this clause in every subcontract so that such terms will be binding on each subcontractor.
- (c) The Contractor shall maintain an accurate record of exposure data on all accidents incident to work performed under this contract resulting in death, traumatic injury, occupational disease, or damage to property, materials, supplies, or equipment, and shall report this data in the manner prescribed by 29 CFR Part 1904.
- (d) The Contracting Officer shall notify the Contractor of any noncompliance with these requirements and of the corrective action required. This notice, when delivered to the Contractor or the Contractor's representative at the site of the work, shall be deemed sufficient notice of the noncompliance and corrective action required. After receiving the notice, the Contractor shall immediately take corrective action. If the Contractor fails or refuses to take corrective action promptly, the Contracting Officer may issue an order stopping all or part of the work until satisfactory corrective action has been taken. The Contractor shall not base any claim or request for equitable adjustment for additional time or money on any stop order issued under these circumstances.
- (e) The Contractor shall be responsible for its subcontractors' compliance with the provisions of this clause. The Contractor shall take such action with respect to any subcontract as the PHA, the Secretary of Housing and Urban Development, or the Secretary of Labor shall direct as a means of enforcing such provisions.

### 14. Temporary Heating

The Contractor shall provide and pay for temporary heating, covering, and enclosures necessary to properly protect all work and materials against damage by dampness and cold, to dry out the work, and to facilitate the completion of the work. Any permanent heating equipment used shall be turned over to the PHA in the condition and at the time required by the specifications.

### 15. Availability and Use of Utility Services

- (a) The PHA shall make all reasonably required amounts of utilities available to the Contractor from existing outlets and supplies, as specified in the contract. Unless otherwise provided in the contract, the amount of each utility service consumed shall be charged to or paid for by the Contractor at prevailing rates charged to the PHA or, where the utility is produced by the PHA, at reasonable rates determined by the Contracting Officer. The Contractor shall carefully conserve any utilities furnished without charge.
- (b) The Contractor, at its expense and in a manner satisfactory to the Contracting Officer, shall install and maintain all necessary temporary connections and distribution lines, and all meters required to measure the amount of each utility used for the purpose of determining charges. Before final acceptance of the work by the PHA, the Contractor shall remove all the temporary connections, distribution lines, meters, and associated paraphernalia.

### 16. Protection of Existing Vegetation, Structures, Equipment, Utilities, and Improvements

- (a) The Contractor shall preserve and protect all structures, equipment, and vegetation (such as trees, shrubs, and grass) on or adjacent to the work site, which are not to be removed under this contract, and which do not unreasonably interfere with the work required under this contract.
- (b) The Contractor shall only remove trees when specifically authorized to do so, and shall avoid damaging vegetation that will remain in place. If any limbs or branches of trees are broken during performance of this contract, or by the careless operation of equipment, or by workmen, the Contractor shall trim those limbs or branches with a clean cut and paint the cut with a tree-pruning compound as directed by the Contracting Officer.
- (c) The Contractor shall protect from damage all existing improvements and utilities (1) at or near the work site and (2) on adjacent property of a third party, the locations of which are made known to or should be known by the Contractor. Prior to disturbing the ground at the construction site, the Contractor shall ensure that all underground utility lines are clearly marked.
- (d) The Contractor shall shore up, brace, underpin, secure, and protect as necessary all foundations and other parts of existing structures adjacent to, adjoining, and in the vicinity of the site, which may be affected by the excavations or other operations connected with the construction of the project.
- (e) Any equipment temporarily removed as a result of work under this contract shall be protected, cleaned, and replaced in the same condition as at the time of award of this contract.

- (f) New work which connects to existing work shall correspond in all respects with that to which it connects and/or be similar to existing work unless otherwise required by the specifications.
- (g) No structural members shall be altered or in any way weakened without the written authorization of the Contracting Officer, unless such work is clearly specified in the plans or specifications.
- (h) If the removal of the existing work exposes discolored or unfinished surfaces, or work out of alignment, such surfaces shall be refinished, or the material replaced as necessary to make the continuous work uniform and harmonious. This, however, shall not be construed to require the refinishing or reconstruction of dissimilar finishes previously exposed, or finished surfaces in good condition, but in different planes or on different levels when brought together by the removal of intervening work, unless such refinishing or reconstruction is specified in the plans or specifications.
- (i) The Contractor shall give all required notices to any adjoining or adjacent property owner or other party before the commencement of any work.
- (j) The Contractor shall indemnify and save harmless the PHA from any damages on account of settlement or the loss of lateral support of adjoining property, any damages from changes in topography affecting drainage, and from all loss or expense and all damages for which the PHA may become liable in consequence of such injury or damage to adjoining and adjacent structures and their premises.
- (k) The Contractor shall repair any damage to vegetation, structures, equipment, utilities, or improvements, including those that are the property of a third party, resulting from failure to comply with the requirements of this contract or failure to exercise reasonable care in performing the work. If the Contractor fails or refuses to repair the damage promptly, the Contracting Officer may have the necessary work performed and charge the cost to the Contractor.

#### **17. Temporary Buildings and Transportation of Materials**

- (a) Temporary buildings (e.g., storage sheds, shops, offices, sanitary facilities) and utilities may be erected by the Contractor only with the approval of the Contracting Officer and shall be built with labor and materials furnished by the Contractor without expense to the PHA. The temporary buildings and utilities shall remain the property of the Contractor and shall be removed by the Contractor at its expense upon completion of the work. With the written consent of the Contracting Officer, the buildings and utilities may be abandoned and need not be removed.
- (b) The Contractor shall, as directed by the Contracting Officer, use only established roadways, or use temporary roadways constructed by the Contractor when and as authorized by the Contracting Officer. When materials are transported in prosecuting the work, vehicles shall not be loaded beyond the loading capacity recommended by the manufacturer of the vehicle or prescribed by any federal, state, or local law or regulation. When it is necessary to cross curbs or sidewalks, the Contractor shall protect them from damage. The Contractor shall repair or pay for the repair of any damaged curbs, sidewalks, or roads.

#### **18. Clean Air and Water**

The contractor shall comply with the Clean Air Act, as amended, 42 USC 7401 et seq., the Federal Water Pollution Control Water Act, as amended, 33 U.S.C. 1251 et seq., and standards issued pursuant thereto in the facilities in which this contract is to be performed.

#### **19. Energy Efficiency**

The Contractor shall comply with mandatory standards and policies relating to energy efficiency which are contained in the energy conservation plan issued in compliance with the Energy Policy and Conservation Act (Pub.L. 94-163) for the State in which the work under the contract is performed.

#### **20. Inspection and Acceptance of Construction**

- (a) Definitions. As used in this clause -
  - (1) "Acceptance" means the act of an authorized representative of the PHA by which the PHA approves and assumes ownership of the work performed under this contract. Acceptance may be partial or complete.
  - (2) "Inspection" means examining and testing the work performed under the contract (including, when appropriate, raw materials, equipment, components, and intermediate assemblies) to determine whether it conforms to contract requirements.
  - (3) "Testing" means that element of inspection that determines the properties or elements, including functional operation of materials, equipment, or their components, by the application of established scientific principles and procedures.
- (b) The Contractor shall maintain an adequate inspection system and perform such inspections as will ensure that the work performed under the contract conforms to contract requirements. All work is subject to PHA inspection and test at all places and at all reasonable times before acceptance to ensure strict compliance with the terms of the contract.
- (c) PHA inspections and tests are for the sole benefit of the PHA and do not: (1) relieve the Contractor of responsibility for providing adequate quality control measures; (2) relieve the Contractor of responsibility for loss or damage of the material before acceptance; (3) constitute or imply acceptance; or, (4) affect the continuing rights of the PHA after acceptance of the completed work under paragraph (j) below.
- (d) The presence or absence of the PHA inspector does not relieve the Contractor from any contract requirement, nor is the inspector authorized to change any term or condition of the specifications without the Contracting Officer's written authorization. All instructions and approvals with respect to the work shall be given to the Contractor by the Contracting Officer.
- (e) The Contractor shall promptly furnish, without additional charge, all facilities, labor, and material reasonably needed for performing such safe and convenient inspections and tests as may be required by the Contracting Officer. The PHA may charge to the Contractor any additional cost of inspection or test when work is not ready at the time specified by the Contractor for inspection or test, or when prior rejection makes reinspection or retest necessary. The PHA shall perform all inspections and tests in a manner that will not unnecessarily delay the work. Special, full size, and performance tests shall be performed as described in the contract.

- (f) The PHA may conduct routine inspections of the construction site on a daily basis.
- (g) The Contractor shall, without charge, replace or correct work found by the PHA not to conform to contract requirements, unless the PHA decides that it is in its interest to accept the work with an appropriate adjustment in contract price. The Contractor shall promptly segregate and remove rejected material from the premises.
- (h) If the Contractor does not promptly replace or correct rejected work, the PHA may (1) by contract or otherwise, replace or correct the work and charge the cost to the Contractor, or (2) terminate for default the Contractor's right to proceed.
- (i) If any work requiring inspection is covered up without approval of the PHA, it must, if requested by the Contracting Officer, be uncovered at the expense of the Contractor. If at any time before final acceptance of the entire work, the PHA considers it necessary or advisable, to examine work already completed by removing or tearing it out, the Contractor, shall on request, promptly furnish all necessary facilities, labor, and material. If such work is found to be defective or nonconforming in any material respect due to the fault of the Contractor or its subcontractors, the Contractor shall defray all the expenses of the examination and of satisfactory reconstruction. If, however, such work is found to meet the requirements of the contract, the Contracting Officer shall make an equitable adjustment to cover the cost of the examination and reconstruction, including, if completion of the work was thereby delayed, an extension of time.
- (j) The Contractor shall notify the Contracting Officer, in writing, as to the date when in its opinion all or a designated portion of the work will be substantially completed and ready for inspection. If the Architect determines that the state of preparedness is as represented, the PHA will promptly arrange for the inspection. Unless otherwise specified in the contract, the PHA shall accept, as soon as practicable after completion and inspection, all work required by the contract or that portion of the work the Contracting Officer determines and designates can be accepted separately. Acceptance shall be final and conclusive except for latent defects, fraud, gross mistakes amounting to fraud, or the PHA's right under any warranty or guarantee.

## 21. Use and Possession Prior to Completion

- (a) The PHA shall have the right to take possession of or use any completed or partially completed part of the work. Before taking possession of or using any work, the Contracting Officer shall furnish the Contractor a list of items of work remaining to be performed or corrected on those portions of the work that the PHA intends to take possession of or use. However, failure of the Contracting Officer to list any item of work shall not relieve the Contractor of responsibility for complying with the terms of the contract. The PHA's possession or use shall not be deemed an acceptance of any work under the contract.
- (b) While the PHA has such possession or use, the Contractor shall be relieved of the responsibility for (1) the loss of or damage to the work resulting from the PHA's possession or use, notwithstanding the terms of the clause entitled Permits and Codes herein; (2) all maintenance costs on the areas occupied; and, (3) furnishing heat, light, power, and water used in the areas

occupied without proper remuneration therefore. If prior possession or use by the PHA delays the progress of the work or causes additional expense to the Contractor, an equitable adjustment shall be made in the contract price or the time of completion, and the contract shall be modified in writing accordingly.

## 22. Warranty of Title

The Contractor warrants good title to all materials, supplies, and equipment incorporated in the work and agrees to deliver the premises together with all improvements thereon free from any claims, liens or charges, and agrees further that neither it nor any other person, firm or corporation shall have any right to a lien upon the premises or anything appurtenant thereto.

## 23. Warranty of Construction

- (a) In addition to any other warranties in this contract, the Contractor warrants, except as provided in paragraph (j) of this clause, that work performed under this contract conforms to the contract requirements and is free of any defect in equipment, material, or workmanship performed by the Contractor or any subcontractor or supplier at any tier. This warranty shall continue for a period of \_\_\_\_\_ (one year unless otherwise indicated) from the date of final acceptance of the work. If the PHA takes possession of any part of the work before final acceptance, this warranty shall continue for a period of (one year unless otherwise indicated) from the date that the PHA takes possession.
- (b) The Contractor shall remedy, at the Contractor's expense, any failure to conform, or any defect. In addition, the Contractor shall remedy, at the Contractor's expense, any damage to PHA-owned or controlled real or personal property when the damage is the result of—
  - (1) The Contractor's failure to conform to contract requirements; or
  - (2) Any defects of equipment, material, workmanship or design furnished by the Contractor.
- (c) The Contractor shall restore any work damaged in fulfilling the terms and conditions of this clause. The Contractor's warranty with respect to work repaired or replaced will run for (one year unless otherwise indicated) from the date of repair or replacement.
- (d) The Contracting Officer shall notify the Contractor, in writing, within a reasonable time after the discovery of any failure, defect or damage.
- (e) If the Contractor fails to remedy any failure, defect, or damage within a reasonable time after receipt of notice, the PHA shall have the right to replace, repair or otherwise remedy the failure, defect, or damage at the Contractor's expense.
- (f) With respect to all warranties, express or implied, from subcontractors, manufacturers, or suppliers for work performed and materials furnished under this contract, the Contractor shall:
  - (1) Obtain all warranties that would be given in normal commercial practice;
  - (2) Require all warranties to be executed in writing, for the benefit of the PHA; and,
  - (3) Enforce all warranties for the benefit of the PHA.
- (g) In the event the Contractor's warranty under paragraph (a) of this clause has expired, the PHA may bring suit at its own expense to enforce a subcontractor's, manufacturer's or supplier's warranty.

- (h) Unless a defect is caused by the negligence of the Contractor or subcontractor or supplier at any tier, the Contractor shall not be liable for the repair of any defect of material or design furnished by the PHA nor for the repair of any damage that results from any defect in PHA furnished material or design.
- (i) Notwithstanding any provisions herein to the contrary, the establishment of the time periods in paragraphs (a) and (c) above relate only to the specific obligation of the Contractor to correct the work, and have no relationship to the time within which its obligation to comply with the contract may be sought to be enforced, nor to the time within which proceedings may be commenced to establish the Contractor's liability with respect to its obligation other than specifically to correct the work.
- (j) This warranty shall not limit the PHA's rights under the Inspection and Acceptance of Construction clause of this contract with respect to latent defects, gross mistakes or fraud.

**24. Prohibition Against Liens**

The Contractor is prohibited from placing a lien on the PHA's property. This prohibition shall apply to all subcontractors at any tier and all materials suppliers.

**Administrative Requirements**

**25. Contract Period**

this contract within \_\_\_\_\_ calendar days of the effective date of the contract, or within the time schedule established in the notice to proceed issued by the Contracting Officer.

**26. Order of Provisions**

In the event of a conflict between these General Conditions and the Specifications, the General Conditions shall prevail. In the event of a conflict between the contract and any applicable state or local law or regulation, the state or local law or regulation shall prevail; provided that such state or local law or regulation does not conflict with, or is less restrictive than applicable federal law, regulation, or Executive Order. In the event of such a conflict, applicable federal law, regulation, and Executive Order shall prevail.

**27. Payments**

- (a) The PHA shall pay the Contractor the price as provided in this contract.
- (b) The PHA shall make progress payments approximately every 30 days as the work proceeds, on estimates of work accomplished which meets the standards of quality established under the contract, as approved by the Contracting Officer. The PHA may, subject to written determination and approval of the Contracting Officer, make more frequent payments to contractors which are qualified small businesses.
- (c) Before the first progress payment under this contract, the Contractor shall furnish, in such detail as requested by the Contracting Officer, a breakdown of the total contract price showing the amount included therein for each principal category of the work, which shall substantiate the payment amount requested in order to provide a

basis for determining progress payments. The breakdown shall be approved by the Contracting Officer and must be acceptable to HUD. If the contract covers more than one project, the Contractor shall furnish a separate breakdown for each. The values and quantities employed in making up this breakdown are for determining the amount of progress payments and shall not be construed as a basis for additions to or deductions from the contract price. The Contractor shall prorate its overhead and profit over the construction period of the contract.

- (d) The Contractor shall submit, on forms provided by the PHA, periodic estimates showing the value of the work performed during each period based upon the approved submitted not later than \_\_\_\_\_ days in advance of the date set for payment and are subject to correction and revision as required. The estimates must be approved by the Contracting Officer with the concurrence of the Architect prior to payment. If the contract covers more than one project, the Contractor shall furnish a separate progress payment estimate for each.
- (e) Along with each request for progress payments and the required estimates, the Contractor shall furnish the following certification, or payment shall not be made: I hereby certify, to the best of my knowledge and belief, that:
  - (1) The amounts requested are only for performance in accordance with the specifications, terms, and conditions of the contract;
  - (2) Payments to subcontractors and suppliers have been made from previous payments received under the contract, and timely payments will be made from the proceeds of the payment covered by this certification, in accordance with subcontract agreements; and,
  - (3) This request for progress payments does not include any amounts which the prime contractor intends to withhold or retain from a subcontractor or supplier in accordance with the terms and conditions of the subcontract.

\_\_\_\_\_  
Name:

\_\_\_\_\_  
Title:

\_\_\_\_\_  
Date:

- (f) Except as otherwise provided in State law, the PHA shall retain ten (10) percent of the amount of progress payments until completion and acceptance of all work under the contract; except, that if upon completion of 50 percent of the work, the Contracting Officer, after consulting with the Architect, determines that the Contractor's performance and progress are satisfactory, the PHA may make the remaining payments in full for the work subsequently completed. If the Contracting Officer subsequently determines that the Contractor's performance and progress are unsatisfactory, the PHA shall reinstate the ten (10) percent (or other percentage as provided in State law) retainage until such time as the Contracting Officer determines that performance and progress are satisfactory.
- (g) The Contracting Officer may authorize material delivered on the site and preparatory work done to be taken into consideration when computing progress payments.

Material delivered to the Contractor at locations other than the site may also be taken into consideration if the Contractor furnishes satisfactory evidence that (1) it has acquired title to such material; (2) the material is properly stored in a bonded warehouse, storage yard, or similar suitable place as may be approved by the Contracting Officer; (3) the material is insured to cover its full value; and (4) the material will be used to perform this contract. Before any progress payment which includes delivered material is made, the Contractor shall furnish such documentation as the Contracting Officer may require to assure the protection of the PHA's interest in such materials. The Contractor shall remain responsible for such stored material notwithstanding the transfer of title to the PHA.

- (h) All material and work covered by progress payments made shall, at the time of payment become the sole property of the PHA, but this shall not be construed as (1) relieving the Contractor from the sole responsibility for all material and work upon which payments have been made or the restoration of any damaged work; or, (2) waiving the right of the PHA to require the fulfillment of all of the terms of the contract. In the event the work of the Contractor has been damaged by other contractors or persons other than employees of the PHA in the course of their employment, the Contractor shall restore such damaged work without cost to the PHA and to seek redress for its damage only from those who directly caused it.
- (i) The PHA shall make the final payment due the Contractor under this contract after (1) completion and final acceptance of all work; and (2) presentation of release of all claims against the PHA arising by virtue of this contract, other than claims, in stated amounts, that the Contractor has specifically excepted from the operation of the release. Each such exception shall embrace no more than one claim, the basis and scope of which shall be clearly defined. The amounts for such excepted claims shall not be included in the request for final payment. A release may also be required of the assignee if the Contractor's claim to amounts payable under this contract has been assigned.
- (j) Prior to making any payment, the Contracting Officer may require the Contractor to furnish receipts or other evidence of payment from all persons performing work and supplying material to the Contractor, if the Contracting Officer determines such evidence is necessary to substantiate claimed costs.
- (k) The PHA shall not; (1) determine or adjust any claims for payment or disputes arising there under between the Contractor and its subcontractors or material suppliers; or, (2) withhold any moneys for the protection of the subcontractors or material suppliers. The failure or refusal of the PHA to withhold moneys from the Contractor shall in no wise impair the obligations of any surety or sureties under any bonds furnished under this contract.

## 28. Contract Modifications

- (a) Only the Contracting Officer has authority to modify any term or condition of this contract. Any contract modification shall be authorized in writing.
- (b) The Contracting Officer may modify the contract unilaterally (1) pursuant to a specific authorization stated in a contract clause (e.g., Changes); or (2) for administrative matters which do not change the rights or

responsibilities of the parties (e.g., change in the PHA address). All other contract modifications shall be in the form of supplemental agreements signed by the Contractor and the Contracting Officer.

- (c) When a proposed modification requires the approval of HUD prior to its issuance (e.g., a change order that exceeds the PHA's approved threshold), such modification shall not be effective until the required approval is received by the PHA.

## 29. Changes

- (a) The Contracting Officer may, at any time, without notice to the sureties, by written order designated or indicated to be a change order, make changes in the work within the general scope of the contract including changes:
  - (1) In the specifications (including drawings and designs);
  - (2) In the method or manner of performance of the work;
  - (3) PHA-furnished facilities, equipment, materials, services, or site; or,
  - (4) Directing the acceleration in the performance of the work.
- (b) Any other written order or oral order (which, as used in this paragraph (b), includes direction, instruction, interpretation, or determination) from the Contracting Officer that causes a change shall be treated as a change order under this clause; provided, that the Contractor gives the Contracting Officer written notice stating (1) the date, circumstances and source of the order and (2) that the Contractor regards the order as a change order.
- (c) Except as provided in this clause, no order, statement or conduct of the Contracting Officer shall be treated as a change under this clause or entitle the Contractor to an equitable adjustment.
- (d) If any change under this clause causes an increase or decrease in the Contractor's cost of, or the time required for the performance of any part of the work under this contract, whether or not changed by any such order, the Contracting Officer shall make an equitable adjustment and modify the contract in writing. However, except for a adjustment based on defective specifications, no proposal for any change under paragraph (b) above shall be allowed for any costs incurred more than 20 days (5 days for oral orders) before the Contractor gives written notice as required. In the case of defective specifications for which the PHA is responsible, the equitable adjustment shall include any increased cost reasonably incurred by the Contractor in attempting to comply with the defective specifications.
- (e) The Contractor must assert its right to an adjustment under this clause within 30 days after (1) receipt of a written change order under paragraph (a) of this clause, or (2) the furnishing of a written notice under paragraph (b) of this clause, by submitting a written statement describing the general nature and the amount of the proposal. If the facts justify it, the Contracting Officer may extend the period for submission. The proposal may be included in the notice required under paragraph (b) above. No proposal by the Contractor for an equitable adjustment shall be allowed if asserted after final payment under this contract.
- (f) The Contractor's written proposal for equitable adjustment shall be submitted in the form of a lump sum proposal supported with an itemized breakdown of all increases and decreases in the contract in at least the following details:

- (1) Direct Costs. Materials (list individual items, the quantity and unit cost of each, and the aggregate cost); Transportation and delivery costs associated with materials; Labor breakdowns by hours or unit costs (identified with specific work to be performed); Construction equipment exclusively necessary for the change; Costs of preparation and/ or revision to shop drawings resulting from the change; Worker's Compensation and Public Liability Insurance; Employment taxes under FICA and FUTA; and, Bond Costs when size of change warrants revision.
- (2) Indirect Costs. Indirect costs may include overhead, general and administrative expenses, and fringe benefits not normally treated as direct costs.
- (3) Profit. The amount of profit shall be negotiated and may vary according to the nature, extent, and complexity of the work required by the change. The allowability of the direct and indirect costs shall be determined in accordance with the Contract Cost Principles and Procedures for Commercial Firms in Part 31 of the Federal Acquisition Regulation (48 CFR 1-31), as implemented by HUD Handbook 2210.18, in effect on the date of this contract. The Contractor shall not be allowed a profit on the profit received by any subcontractor. Equitable adjustments for deleted work shall include a credit for profit and may include a credit for indirect costs. On proposals covering both increases and decreases in the amount of the contract, the application of indirect costs and profit shall be on the net-change in direct costs for the Contractor or subcontractor performing the work.
- (g) The Contractor shall include in the proposal its request for time extension (if any), and shall include sufficient information and dates to demonstrate whether and to what extent the change will delay the completion of the contract in its entirety.
- (h) The Contracting Officer shall act on proposals within 30 days after their receipt, or notify the Contractor of the date when such action will be taken.
- (i) Failure to reach an agreement on any proposal shall be a dispute under the clause entitled Disputes herein. Nothing in this clause, however, shall excuse the Contractor from proceeding with the contract as changed.
- (j) Except in an emergency endangering life or property, no change shall be made by the Contractor without a prior order from the Contracting Officer.

### 30. Suspension of Work

- (a) The Contracting Officer may order the Contractor in writing to suspend, delay, or interrupt all or any part of the work of this contract for the period of time that the Contracting Officer determines appropriate for the convenience of the PHA.
- (b) If the performance of all or any part of the work is, for an unreasonable period of time, suspended, delayed, or interrupted (1) by an act of the Contracting Officer in the administration of this contract, or (2) by the Contracting Officer's failure to act within the time specified (or within a reasonable time if not specified) in this contract an adjustment shall be made for any increase in the cost of performance of the contract (excluding profit) necessarily caused by such unreasonable suspension, delay, or interruption and the contract modified in writing accordingly. However, no adjustment shall be made under this clause for any suspension, delay, or interruption to the extent that performance would have

been so suspended, delayed, or interrupted by any other cause, including the fault or negligence of the Contractor or for which any equitable adjustment is provided for or excluded under any other provision of this contract.

- (c) A claim under this clause shall not be allowed (1) for any costs incurred more than 20 days before the Contractor shall have notified the Contracting Officer in writing of the act or failure to act involved (but this requirement shall not apply as to a claim resulting from a suspension order); and, (2) unless the claim, in an amount stated, is asserted in writing as soon as practicable after the termination of the suspension, delay, or interruption, but not later than the date of final payment under the contract.

### 31. Disputes

- (a) "Claim," as used in this clause, means a written demand or written assertion by one of the contracting parties seeking, as a matter of right, the payment of money in a sum certain, the adjustment or interpretation of contract terms, or other relief arising under or relating to the contract. A claim arising under the contract, unlike a claim relating to the contract, is a claim that can be resolved under a contract clause that provides for the relief sought by the claimant. A voucher, invoice, or other routine request for payment that is not in dispute when submitted is not a claim. The submission may be converted to a claim by complying with the requirements of this clause, if it is disputed either as to liability or amount or is not acted upon in a reasonable time.
- (b) Except for disputes arising under the clauses entitled Labor Standards - Davis Bacon and Related Acts, herein, all disputes arising under or relating to this contract, including any claims for damages for the alleged breach thereof which are not disposed of by agreement, shall be resolved under this clause.
- (c) All claims by the Contractor shall be made in writing and submitted to the Contracting Officer for a written decision. A claim by the PHA against the Contractor shall be subject to a written decision by the Contracting Officer.
- (d) The Contracting Officer shall, within 60 (unless otherwise indicated) days after receipt of the request, decide the claim or notify the Contractor of the date by which the decision will be made.
- (e) The Contracting Officer's decision shall be final unless the Contractor (1) appeals in writing to a higher level in the PHA in accordance with the PHA's policy and procedures, (2) refers the appeal to an independent mediator or arbitrator, or (3) files suit in a court of competent jurisdiction. Such appeal must be made within (30 unless otherwise indicated) days after receipt of the Contracting Officer's decision.
- (f) The Contractor shall proceed diligently with performance of this contract, pending final resolution of any request for relief, claim, appeal, or action arising under or relating to the contract, and comply with any decision of the Contracting Officer.

### 32. Default

- (a) If the Contractor refuses or fails to prosecute the work, or any separable part thereof, with the diligence that will insure its completion within the time specified in this contract, or any extension thereof, or fails to complete said work within this time, the Contracting Officer may, by written notice to the Contractor, terminate the right to

proceed with the work (or separable part of the work) that has been delayed. In this event, the PHA may take over the work and complete it, by contract or otherwise, and may take possession of and use any materials, equipment, and plant on the work site necessary for completing the work. The Contractor and its sureties shall be liable for any damage to the PHA resulting from the Contractor's refusal or failure to complete the work within the specified time, whether or not the Contractor's right to proceed with the work is terminated. This liability includes any increased costs incurred by the PHA in completing the work.

- (b) The Contractor's right to proceed shall not be terminated or the Contractor charged with damages under this clause if—
- (1) The delay in completing the work arises from unforeseeable causes beyond the control and without the fault or negligence of the Contractor. Examples of such causes include (i) acts of God, or of the public enemy, (ii) acts of the PHA or other governmental entity in either its sovereign or contractual capacity, (iii) acts of another contractor in the performance of a contract with the PHA, (iv) fires, (v) floods, (vi) epidemics, (vii) quarantine restrictions, (viii) strikes, (ix) freight embargoes, (x) unusually severe weather, or (xi) delays of subcontractors or suppliers at any tier arising from unforeseeable causes beyond the control and without the fault or negligence of both the Contractor and the subcontractors or suppliers; and
  - (2) The Contractor, within days (10 days unless otherwise indicated) from the beginning of such delay (unless extended by the Contracting Officer) notifies the Contracting Officer in writing of the causes of delay. The Contracting Officer shall ascertain the facts and the extent of the delay. If, in the judgment of the Contracting Officer, the findings of fact warrant such action, time for completing the work shall be extended by written modification to the contract. The findings of the Contracting Officer shall be reduced to a written decision which shall be subject to the provisions of the Disputes clause of this contract.
- (c) If, after termination of the Contractor's right to proceed, it is determined that the Contractor was not in default, or that the delay was excusable, the rights and obligations of the parties will be the same as if the termination had been for convenience of the PHA.

### 33. Liquidated Damages

- (a) If the Contractor fails to complete the work within the time specified in the contract, or any extension, as specified in the clause entitled Default of this contract, the Contractor shall pay to the PHA as liquidated damages, the sum of \$ \_\_\_\_\_ [Contracting Officer insert amount] for each day of delay. If different completion dates are specified in the contract for separate parts or stages of the work, the amount of liquidated damages shall be assessed on those parts or stages which are delayed. To the extent that the Contractor's delay or nonperformance is excused under another clause in this contract, liquidated damages shall not be due the PHA. The Contractor remains liable for damages caused other than by delay.
- (b) If the PHA terminates the Contractor's right to proceed, the resulting damage will consist of liquidated damages until such reasonable time as may be required for final

completion of the work together with any increased costs occasioned the PHA in completing the work.

- (c) If the PHA does not terminate the Contractor's right to proceed, the resulting damage will consist of liquidated damages until the work is completed or accepted.

### 34. Termination for Convenience

- (a) The Contracting Officer may terminate this contract in whole, or in part, whenever the Contracting Officer determines that such termination is in the best interest of the PHA. Any such termination shall be effected by delivery to the Contractor of a Notice of Termination specifying the extent to which the performance of the work under the contract is terminated, and the date upon which such termination becomes effective.
- (b) If the performance of the work is terminated, either in whole or in part, the PHA shall be liable to the Contractor for reasonable and proper costs resulting from such termination upon the receipt by the PHA of a properly presented claim setting out in detail: (1) the total cost of the work performed to date of termination less the total amount of contract payments made to the Contractor; (2) the cost (including reasonable profit) of settling and paying claims under subcontracts and material orders for work performed and materials and supplies delivered to the site, payment for which has not been made by the PHA to the Contractor or by the Contractor to the subcontractor or supplier; (3) the cost of preserving and protecting the work already performed until the PHA or assignee takes possession thereof or assumes responsibility therefore; (4) the actual or estimated cost of legal and accounting services reasonably necessary to prepare and present the termination claim to the PHA; and (5) an amount constituting a reasonable profit on the value of the work performed by the Contractor.
- (c) The Contracting Officer will act on the Contractor's claim within days (60 days unless otherwise indicated) of receipt of the Contractor's claim.
- (d) Any disputes with regard to this clause are expressly made subject to the provisions of the Disputes clause of this contract.

### 35. Assignment of Contract

The Contractor shall not assign or transfer any interest in this contract; except that claims for monies due or to become due from the PHA under the contract may be assigned to a bank, trust company, or other financial institution. Such assignments of claims shall only be made with the written concurrence of the Contracting Officer. If the Contractor is a partnership, this contract shall inure to the benefit of the surviving or remaining member(s) of such partnership as approved by the Contracting Officer.

### 36. Insurance

- (a) Before commencing work, the Contractor and each subcontractor shall furnish the PHA with certificates of insurance showing the following insurance is in force and will insure all operations under the Contract:
- (1) Workers' Compensation, in accordance with state or Territorial Workers' Compensation laws.
  - (2) Commercial General Liability with a combined single limit for bodily injury and property damage of not less than \$ \_\_\_\_\_ [Contracting Officer insert amount]



per occurrence to protect the Contractor and each subcontractor against claims for bodily injury or death and damage to the property of others. This shall cover the use of all equipment, hoists, and vehicles on the site(s) not covered by Automobile Liability under (3) below. If the Contractor has a "claims made" policy, then the following additional requirements apply: the policy must provide a "retroactive date" which must be on or before the execution date of the Contract; and the extended reporting period may not be less than five years following the completion date of the Contract.

- (3) Automobile Liability on owned and non-owned motor vehicles used on the site(s) or in connection therewith for a combined single limit for bodily injury and property damage of not less than \$ \_\_\_\_\_ [Contracting Officer insert amount] per occurrence.
- (b) Before commencing work, the Contractor shall furnish the PHA with a certificate of insurance evidencing that Builder's Risk (fire and extended coverage) Insurance on all work in place and/or materials stored at the building site(s), including foundations and building equipment, is in force. The Builder's Risk Insurance shall be for the benefit of the Contractor and the PHA as their interests may appear and each shall be named in the policy or policies as an insured. The Contractor in installing equipment supplied by the PHA shall carry insurance on such equipment from the time the Contractor takes possession thereof until the Contract work is accepted by the PHA. The Builder's Risk Insurance need not be carried on excavations, piers, footings, or foundations until such time as work on the superstructure is started. It need not be carried on landscape work. Policies shall furnish coverage at all times for the full cash value of all completed construction, as well as materials in place and/or stored at the site(s), whether or not partial payment has been made by the PHA. The Contractor may terminate this insurance on buildings as of the date taken over for occupancy by the PHA. The Contractor is not required to carry Builder's Risk Insurance for modernization work which does not involve structural alterations or additions and where the PHA's existing fire and extended coverage policy can be endorsed to include such work.
- (c) All insurance shall be carried with companies which are financially responsible and admitted to do business in the State in which the project is located. If any such insurance is due to expire during the construction period, the Contractor (including subcontractors, as applicable) shall not permit the coverage to lapse and shall furnish evidence of coverage to the Contracting Officer. All certificates of insurance, as evidence of coverage, shall provide that no coverage may be canceled or non-renewed by the insurance company until at least 30 days prior written notice has been given to the Contracting Officer.

### 37. Subcontracts

- (a) Definitions. As used in this contract -
- (1) "Subcontract" means any contract, purchase order, or other purchase agreement, including modifications and change orders to the foregoing, entered into by a subcontractor to furnish supplies, materials, equipment, and services for the performance of the prime contract or a subcontract.

(2) "Subcontractor" means any supplier, vendor, or firm that furnishes supplies, materials, equipment, or services to or for the Contractor or another subcontractor.

- (b) The Contractor shall not enter into any subcontract with any subcontractor who has been temporarily denied participation in a HUD program or who has been suspended or debarred from participating in contracting programs by any agency of the United States Government or of the state in which the work under this contract is to be performed.
- (c) The Contractor shall be as fully responsible for the acts or omissions of its subcontractors, and of persons either directly or indirectly employed by them as for the acts or omissions of persons directly employed by the Contractor.
- (d) The Contractor shall insert appropriate clauses in all subcontracts to bind subcontractors to the terms and conditions of this contract insofar as they are applicable to the work of subcontractors.
- (e) Nothing contained in this contract shall create any contractual relationship between any subcontractor and the PHA or between the subcontractor and HUD.

### 38. Subcontracting with Small and Minority Firms, Women's Business Enterprise, and Labor Surplus Area Firms

The Contractor shall take the following steps to ensure that, whenever possible, subcontracts are awarded to small business firms, minority firms, women's business enterprises, and labor surplus area firms:

- (a) Placing qualified small and minority businesses and women's business enterprises on solicitation lists;
- (b) Ensuring that small and minority businesses and women's business enterprises are solicited whenever they are potential sources;
- (c) Dividing total requirements, when economically feasible, into smaller tasks or quantities to permit maximum participation by small and minority businesses and women's business enterprises;
- (d) Establishing delivery schedules, where the requirements of the contract permit, which encourage participation by small and minority businesses and women's business enterprises; and
- (e) Using the services and assistance of the U.S. Small Business Administration, the Minority Business Development Agency of the U.S. Department of Commerce, and State and local governmental small business agencies.

### 39. Equal Employment Opportunity

During the performance of this contract, the Contractor agrees as follows:

- (a) The Contractor shall not discriminate against any employee or applicant for employment because of race, color, religion, sex, national origin, or handicap.
- (b) The Contractor shall take affirmative action to ensure that applicants are employed, and that employees are treated during employment without regard to their race, color, religion, sex, national origin, or handicap. Such action shall include, but not be limited to, (1) employment, (2) upgrading, (3) demotion, (4) transfer, (5) recruitment or recruitment advertising, (6) layoff or termination, (7) rates of pay or other forms of compensation, and (8) selection for training, including apprenticeship.

- (c) The Contractor shall post in conspicuous places available to employees and applicants for employment the notices to be provided by the Contracting Officer that explain this clause.
- (d) The Contractor shall, in all solicitations or advertisements for employees placed by or on behalf of the Contractor, state that all qualified applicants will receive consideration for employment without regard to race, color, religion, sex, national origin, or handicap.
- (e) The Contractor shall send, to each labor union or representative of workers with which it has a collective bargaining agreement or other contract or understanding, the notice to be provided by the Contracting Officer advising the labor union or workers' representative of the Contractor's commitments under this clause, and post copies of the notice in conspicuous places available to employees and applicants for employment.
- (f) The Contractor shall comply with Executive Order 11246, as amended, and the rules, regulations, and orders of the Secretary of Labor.
- (g) The Contractor shall furnish all information and reports required by Executive Order 11246, as amended, Section 503 of the Rehabilitation Act of 1973, as amended, and by rules, regulations, and orders of the Secretary of Labor, or pursuant thereto. The Contractor shall permit access to its books, records, and accounts by the Secretary of Labor for purposes of investigation to ascertain compliance with such rules, regulations, and orders.
- (h) In the event of a determination that the Contractor is not in compliance with this clause or any rule, regulation, or order of the Secretary of Labor, this contract may be canceled, terminated, or suspended in whole or in part, and the Contractor may be declared ineligible for further Government contracts, or Federally assisted construction contracts under the procedures authorized in Executive Order 11246, as amended. In addition, sanctions may be imposed and remedies invoked against the Contractor as provided in Executive Order 11246, as amended, the rules, regulations, and orders of the Secretary of Labor, or as otherwise provided by law.
- (i) The Contractor shall include the terms and conditions of this clause in every subcontract or purchase order unless exempted by the rules, regulations, or orders of the Secretary of Labor issued under Executive Order 11246, as amended, so that these terms and conditions will be binding upon each subcontractor or vendor. The Contractor shall take such action with respect to any subcontract or purchase order as the Secretary of Housing and Urban Development or the Secretary of Labor may direct as a means of enforcing such provisions, including sanctions for noncompliance; provided that if the Contractor becomes involved in, or is threatened with, litigation with a subcontractor or vendor as a result of such direction, the Contractor may request the United States to enter into the litigation to protect the interests of the United States.
- (j) Compliance with the requirements of this clause shall be to the maximum extent consistent with, but not in derogation of, compliance with section 7(b) of the Indian Self-Determination and Education Assistance Act and the Indian Preference clause of this contract.

**40. Employment, Training, and Contracting Opportunities for Low-Income Persons, Section 3 of the Housing and Urban Development Act of 1968.**

- (a) The work to be performed under this contract is subject to the requirements of section 3 of the Housing and Urban Development Act of 1968, as amended, 12 U.S.C. 1701u (section 3). The purpose of section 3 is to ensure that employment and other economic opportunities generated by HUD assistance or HUD-assisted projects covered by section 3, shall, to the greatest extent feasible, be directed to low- and very low-income persons, particularly persons who are recipients of HUD assistance for housing.
- (b) The parties to this contract agree to comply with HUD's regulations in 24 CFR Part 135, which implement section 3. As evidenced by their execution of this contract, the parties to this contract certify that they are under no contractual or other impediment that would prevent them from complying with the Part 135 regulations.
- (c) The contractor agrees to send to each labor organization or representative of workers with which the contractor has a collective bargaining agreement or other understanding, if any, a notice advising the labor organization or workers' representative of the contractor's commitments under this section 3 clause, and will post copies of the notice in conspicuous places at the work site where both employees and applicants for training and employment positions can see the notice. The notice shall describe the section 3 preference, shall set forth minimum number and job titles subject to hire, availability of apprenticeship and training positions, the qualifications for each; and the name and location of the person(s) taking applications for each of the positions; and the anticipated date the work shall begin.
- (d) The contractor agrees to include this section 3 clause in every subcontract subject to compliance with regulations in 24 CFR Part 135, and agrees to take appropriate action, as provided in an applicable provision of the subcontract or in this section 3 clause, upon a finding that the subcontractor is in violation of the regulations in 24 CFR Part 135. The contractor will not subcontract with any subcontractor where the contractor has notice or knowledge that the subcontractor has been found in violation of the regulations in 24 CFR Part 135.
- (e) The contractor will certify that any vacant employment positions, including training positions, that are filled (1) after the contractor is selected but before the contract is executed, and (2) with persons other than those to whom the regulations of 24 CFR Part 135 require employment opportunities to be directed, were not filled to circumvent the contractor's obligations under 24 CFR Part 135.
- (f) Noncompliance with HUD's regulations in 24 CFR Part 135 may result in sanctions, termination of this contract for default, and debarment or suspension from future HUD assisted contracts.
- (g) With respect to work performed in connection with section 3 covered Indian housing assistance, section 7(b) of the Indian Self-Determination and Education Assistance Act (25 U.S.C. 450e) also applies to the work to be performed under this contract. Section 7(b) requires that to the greatest extent feasible (i) preference and opportunities for training and employment shall be given to Indians, and (ii) preference in the award of contracts and subcontracts shall be given to Indian organizations and Indian-owned Economic Enterprises. Parties to this contract that are subject to the provisions of section 3 and section 7(b) agree to comply with section 3 to the maximum extent feasible, but not in derogation of compliance with section 7(b).

---

#### 41. Interest of Members of Congress

No member of or delegate to the Congress of the United States of America shall be admitted to any share or part of this contract or to any benefit that may arise therefrom.

#### 42. Interest of Members, Officers, or Employees and Former Members, Officers, or Employees

No member, officer, or employee of the PHA, no member of the governing body of the locality in which the project is situated, no member of the governing body of the locality in which the PHA was activated, and no other public official of such locality or localities who exercises any functions or responsibilities with respect to the project, shall, during his or her tenure, or for one year thereafter, have any interest, direct or indirect, in this contract or the proceeds thereof.

#### 43. Limitations on Payments made to Influence Certain Federal Financial Transactions

- (a) The Contractor agrees to comply with Section 1352 of Title 31, United States Code which prohibits the use of Federal appropriated funds to pay any person for influencing or attempting to influence an officer or employee of any agency, a Member of Congress, and officer or employee of Congress, or an employee of a Member of Congress in connection with any of the following covered Federal actions: the awarding of any Federal contract; the making of any Federal grant; the making of any Federal loan; the entering into of any cooperative agreement; or the modification of any Federal contract, grant, loan, or cooperative agreement.
- (b) The Contractor further agrees to comply with the requirement of the Act to furnish a disclosure (OMB Standard Form LLL, Disclosure of Lobbying Activities) if any funds other than Federal appropriated funds (including profit or fee received under a covered Federal transaction) have been paid, or will be paid, to any person for influencing or attempting to influence an officer or employee of any agency, a Member of Congress, an officer or employee of Congress, or an employee of a Member of Congress in connection with a Federal contract, grant, loan, or cooperative agreement.

#### 44. Royalties and Patents

The Contractor shall pay all royalties and license fees. It shall defend all suits or claims for infringement of any patent rights and shall save the PHA harmless from loss on account thereof; except that the PHA shall be responsible for all such loss when a particular design, process or the product of a particular manufacturer or manufacturers is specified and the Contractor has no reason to believe that the specified design, process, or product is an infringement. If, however, the Contractor has reason to believe that any design, process or product specified is an infringement of a patent, the Contractor shall promptly notify the Contracting Officer. Failure to give such notice shall make the Contractor responsible for resultant loss.

#### 45. Examination and Retention of Contractor's Records

- (a) The PHA, HUD, or Comptroller General of the United States, or any of their duly authorized representatives shall, until 3 years after final payment under this contract, have access to and the right to examine any of the Contractor's directly pertinent books, documents, papers, or other records involving transactions related to this contract for the purpose of making audit, examination, excerpts, and transcriptions.
- (b) The Contractor agrees to include in first-tier subcontracts under this contract a clause substantially the same as paragraph (a) above. "Subcontract," as used in this clause, excludes purchase orders not exceeding \$10,000.
- (c) The periods of access and examination in paragraphs (a) and (b) above for records relating to (1) appeals under the Disputes clause of this contract, (2) litigation or settlement of claims arising from the performance of this contract, or (3) costs and expenses of this contract to which the PHA, HUD, or Comptroller General or any of their duly authorized representatives has taken exception shall continue until disposition of such appeals, litigation, claims, or exceptions.

#### 46. Labor Standards - Davis-Bacon and Related Acts

If the total amount of this contract exceeds \$2,000, the Federal labor standards set forth in the clause below shall apply to the development or construction work to be performed under the contract.

- (a) Minimum Wages.
  - (1) All laborers and mechanics employed under this contract in the development or construction of the project(s) involved will be paid unconditionally and not less often than once a week, and without subsequent deduction or rebate on any account (except such payroll deductions as are permitted by regulations issued by the Secretary of Labor under the Copeland Act (29 CFR Part 3)), the full amount of wages and bona fide fringe benefits (or cash equivalents thereof) due at time of payment computed at rates not less than those contained in the wage determination of the Secretary of Labor which is attached hereto and made a part hereof, regardless of any contractual relationship which may be alleged to exist between the Contractor and such laborers and mechanics. Contributions made or costs reasonably anticipated for bona fide fringe benefits under Section 1(b)(2) of the Davis-Bacon Act on behalf of laborers or mechanics are considered wages paid to such laborers or mechanics, subject to the provisions of 29 CFR 5.5(a)(1)(iv); also, regular contributions made or costs incurred for more than a weekly period (but not less often than quarterly) under plans, funds, or programs which cover the regular weekly period, are deemed to be constructively made or incurred during such weekly period. Such laborers and mechanics shall be paid the appropriate wage rate and fringe benefits in the wage determination for the classification of work actually performed, without regard to skill, except as provided in 29 CFR 5.5(a)(4). Laborers or mechanics performing work in more than one classification may be compensated at the rate specified for each classification for the time actually worked therein; provided, that the employer's payroll records accurately set forth the time spent in each classification in which work is performed. The wage determination (including any additional classification and wage rates conformed under 29 CFR 5.5(a)(1)(ii) and the Davis-Bacon poster (WH-1321) shall

---

be posted at all times by the Contractor and its subcontractors at the site of the work in a prominent and accessible place where it can be easily seen by the workers.

- (2) (i) Any class of laborers or mechanics, including helpers, which is not listed in the wage determination and which is to be employed under the contract shall be classified in conformance with the wage determination. HUD shall approve an additional classification and wage rate and fringe benefits therefor only when all the following criteria have been met: (A) The work to be performed by the classification requested is not performed by a classification in the wage determination; and (B) The classification is utilized in the area by the construction industry; and (C) The proposed wage rate, including any bona fide fringe benefits, bears a reasonable relationship to the wage rates contained in the wage determination.
- (ii) If the Contractor and the laborers and mechanics to be employed in the classification (if known), or their representatives, and HUD or its designee agree on the classification and wage rate (including the amount designated for fringe benefits where appropriate), a report of the action taken shall be sent by HUD or its designee to the Administrator of the Wage and Hour Division, Employee Standards Administration, U.S. Department of Labor, Washington, DC 20210. The Administrator, or an authorized representative, will approve, modify, or disapprove every additional classification action within 30 days of receipt and so advise HUD or its designee or will notify HUD or its designee within the 30-day period that additional time is necessary.
- (iii) In the event the Contractor, the laborers or mechanics to be employed in the classification or their representatives, and HUD or its designee do not agree on the proposed classification and wage rate (including the amount designated for fringe benefits, where appropriate), HUD or its designee shall refer the questions, including the views of all interested parties and the recommendation of HUD or its designee, to the Administrator of the Wage and Hour Division for determination. The Administrator, or an authorized representative, will issue a determination within 30 days of receipt and so advise HUD or its designee or will notify HUD or its designee within the 30-day period that additional time is necessary.
- (iv) The wage rate (including fringe benefits where appropriate) determined pursuant to subparagraphs (a)(2)(ii) or (iii) of this clause shall be paid to all workers performing work in the classification under this contract from the first day on which work is performed in classification.
- (3) Whenever the minimum wage rate prescribed in the contract for a class of laborers or mechanics includes a fringe benefit which is not expressed as an hourly rate, the Contractor shall either pay the benefit as stated in the wage determination or shall pay another bona fide fringe benefit or an hourly cash equivalent thereof.
- (4) If the Contractor does not make payments to a trustee or other third person, the Contractor may consider as part of the wages of any laborer or mechanic the

amount of any costs reasonably anticipated in providing bona fide fringe benefits under a plan or program; provided, that the Secretary of Labor has found, upon the written request of the Contractor, that the applicable standards of the Davis-Bacon Act have been met. The Secretary of Labor may require the Contractor to set aside in a separate account assets for the meeting of obligations under the plan or program.

- (b) Withholding of funds. HUD or its designee shall, upon its own action or upon written request of an authorized representative of the Department of Labor, withhold or cause to be withheld from the Contractor under this contract or any other Federal contract with the same prime Contractor, or any other Federally-assisted contract subject to Davis-Bacon prevailing wage requirements, which is held by the same prime Contractor, so much of the accrued payments or advances as may be considered necessary to pay laborers and mechanics, including apprentices, trainees, and helpers, employed by the Contractor or any subcontractor the full amount of wages required by the contract. In the event of failure to pay any laborer or mechanic, including any apprentice, trainee, or helper, employed or working in the construction or development of the project, all or part of the wages required by the contract, HUD or its designee may, after written notice to the Contractor, take such action as may be necessary to cause the suspension of any further payment, advance, or guarantee of funds until such violations have ceased. HUD or its designee may, after written notice to the Contractor, disburse such amounts withheld for and on account of the Contractor or subcontractor to the respective employees to whom they are due.
- (c) Payrolls and basic records.
- (1) Payrolls and basic records relating thereto shall be maintained by the Contractor during the course of the work and preserved for a period of three years thereafter for all laborers and mechanics working in the construction or development of the project. Such records shall contain the name, address, and social security number of each such worker, his or her correct classification, hourly rates of wages paid (including rates of contributions or costs anticipated for bona fide fringe benefits or cash equivalents thereof of the types described in section 1(b)(2)(B) of the Davis-Bacon Act), daily and weekly number of hours worked, deductions made, and actual wages paid. Whenever the Secretary of Labor has found, under 29 CFR 5.5(a)(1)(iv), that the wages of any laborer or mechanic include the amount of costs reasonably anticipated in providing benefits under a plan or program described in section 1(b)(2)(B) of the Davis-Bacon Act, the Contractor shall maintain records which show that the commitment to provide such benefits is enforceable, that the plan or program is financially responsible, and that the plan or program has been communicated in writing to the laborers or mechanics affected, and records which show the costs anticipated or the actual cost incurred in providing such benefits. Contractors employing apprentices or trainees under approved programs shall maintain written evidence of the registration of apprenticeship programs and certification of trainee programs, the registration of the apprentices and trainees, and the ratios and wage rates prescribed in the applicable programs.

- (2) (i) The Contractor shall submit weekly for each week in which any contract work is performed a copy of all payrolls to the Contracting Officer for transmission to HUD or its designee. The payrolls submitted shall set out accurately and completely all of the information required to be maintained under subparagraph (c)(1) of this clause. This information may be submitted in any form desired. Optional Form WH-347 (Federal Stock Number 029-005-00014-1) is available for this purpose and may be purchased from the Superintendent of Documents, U.S. Government Printing Office, Washington, D.C. 20402. The Contractor is responsible for the submission of copies of payrolls by all subcontractors. (Approved by the Office of Management and Budget under OMB Control Number 1214-0149.)
- (ii) Each payroll submitted shall be accompanied by a "Statement of Compliance," signed by the Contractor or subcontractor or his or her agent who pays or supervises the payment of the persons employed under the contract and shall certify the following:
- (A) That the payroll for the payroll period contains the information required to be maintained under paragraph (c) (1) of this clause and that such information is correct and complete;
- (B) That each laborer or mechanic (including each helper, apprentice, and trainee) employed on the contract during the payroll period has been paid the full weekly wages earned, without rebate, either directly or indirectly, and that no deductions have been made either directly or indirectly from the full wages earned, other than permissible deductions as set forth in 29 CFR Part 3; and
- (C) That each laborer or mechanic has been paid not less than the applicable wage rates and fringe benefits or cash equivalents for the classification of work performed, as specified in the applicable wage determination incorporated into the contract.
- (iii) The weekly submission of a properly executed certification set forth on the reverse side of Optional Form WH-347 shall satisfy the requirements for submission of the "Statement of Compliance" required by subparagraph (c)(2)(ii) of this clause.
- (iv) The falsification of any of the above certifications may subject the Contractor or subcontractor to civil or criminal prosecution under Section 1001 of Title 18 and Section 3729 of Title 31 of the United States Code.
- (3) The Contractor or subcontractor shall make the records required under subparagraph (c)(1) available for inspection, copying, or transcription by authorized representatives of HUD or its designee, the Contracting Officer, or the Department of Labor and shall permit such representatives to interview employees during working hours on the job. If the Contractor or subcontractor fails to submit the required records or to make them available, HUD or its designee may, after written notice to the Contractor, take such action as may be necessary to cause the suspension of any further payment, advance, or guarantee of funds. Furthermore, failure to submit the required records upon request or to

make such records available may be grounds for debarment action pursuant to 29 CFR 5.12.

- (d) (1) Apprentices. Apprentices will be permitted to work at less than the predetermined rate for the work they performed when they are employed pursuant to and individually registered in a bona fide apprenticeship program registered with the U.S. Department of Labor, Employment and Training Administration, Office of Apprenticeship and Training, Employer and Labor Services (OATELS), or with a State Apprenticeship Agency recognized by OATELS, or if a person is employed in his or her first 90 days of probationary employment as an apprentice in such an apprenticeship program, who is not individually registered in the program, but who has been certified by OATELS or a State Apprenticeship Agency (where appropriate) to be eligible for probationary employment as an apprentice. The allowable ratio of apprentices to journeymen on the job site in any craft classification shall not be greater than the ratio permitted to the Contractor as to the entire work force under the registered program. Any worker listed on a payroll at an apprentice wage rate, who is not registered or otherwise employed as stated in this paragraph, shall be paid not less than the applicable wage rate on the wage determination for the classification of work actually performed. In addition, any apprentice performing work on the job site in excess of the ratio permitted under the registered program shall be paid not less than the applicable wage rate on the wage determination for the work actually performed. Where a contractor is performing construction on a project in a locality other than that in which its program is registered, the ratios and wage rates (expressed in percentages of the journeyman's hourly rate) specified in the Contractor's or subcontractor's registered program shall be observed. Every apprentice must be paid at not less than the rate specified in the registered program for the apprentice's level of progress, expressed as a percentage of the journeyman hourly rate specified in the applicable wage determination. Apprentices shall be paid fringe benefits in accordance with the provisions of the apprenticeship program. If the apprenticeship program does not specify fringe benefits, apprentices must be paid the full amount of fringe benefits listed on the wage determination for the applicable classification. If the Administrator of the Wage and Hour Division determines that a different practice prevails for the applicable apprentice classification, fringes shall be paid in accordance with that determination. In the event OATELS, or a State Apprenticeship Agency recognized by OATELS, withdraws approval of an apprenticeship program, the Contractor will no longer be permitted to utilize apprentices at less than the applicable predetermined rate for the work performed until an acceptable program is approved.
- (2) Trainees. Except as provided in 29 CFR 5.16, trainees will not be permitted to work at less than the predetermined rate for the work performed unless they are employed pursuant to and individually registered in a program which has received prior approval, evidenced by formal certification by the U.S. Department of Labor, Employment and Training Administration. The ratio of trainees to journeymen on the job site shall not be greater than permitted under

the plan approved by the Employment and Training Administration. Every trainee must be paid at not less than the rate specified in the approved program for the trainee's level of progress, expressed as a percentage of the journeyman hourly rate specified in the applicable wage determination. Trainees shall be paid fringe benefits in accordance with the provisions of the trainee program. If the trainee program does not mention fringe benefits, trainees shall be paid the full amount of fringe benefits listed in the wage determination unless the Administrator of the Wage and Hour Division determines that there is an apprenticeship program associated with the corresponding journeyman wage rate in the wage determination which provides for less than full fringe benefits for apprentices. Any employee listed on the payroll at a trainee rate who is not registered and participating in a training plan approved by the Employment and Training Administration shall be paid not less than the applicable wage rate in the wage determination for the classification of work actually performed. In addition, any trainee performing work on the job site in excess of the ratio permitted under the registered program shall be paid not less than the applicable wage rate in the wage determination for the work actually performed. In the event the Employment and Training Administration withdraws approval of a training program, the Contractor will no longer be permitted to utilize trainees at less than the applicable predetermined rate for the work performed until an acceptable program is approved.

- (3) Equal employment opportunity. The utilization of apprentices, trainees, and journeymen under this clause shall be in conformity with the equal employment opportunity requirements of Executive Order 11246, as amended, and 29 CFR Part 30.
- (e) Compliance with Copeland Act requirements. The Contractor shall comply with the requirements of 29 CFR Part 3, which are hereby incorporated by reference in this contract.
- (f) Contract termination; debarment. A breach of this contract clause may be grounds for termination of the contract and for debarment as a Contractor and a subcontractor as provided in 29 CFR 5.12.
- (g) Compliance with Davis-Bacon and related Act requirements. All rulings and interpretations of the Davis-Bacon and related Acts contained in 29 CFR Parts 1, 3, and 5 are herein incorporated by reference in this contract.
- (h) Disputes concerning labor standards. Disputes arising out of the labor standards provisions of this clause shall not be subject to the general disputes clause of this contract. Such disputes shall be resolved in accordance with the procedures of the Department of Labor set forth in 29 CFR Parts 5, 6, and 7. Disputes within the meaning of this clause include disputes between the Contractor (or any of its subcontractors) and the PHA, HUD, the U.S. Department of Labor, or the employees or their representatives.
- (i) Certification of eligibility.
  - (1) By entering into this contract, the Contractor certifies that neither it (nor he or she) nor any person or firm who has an interest in the Contractor's firm is a person or firm ineligible to be awarded contracts by the United States Government by virtue of section 3(a) of the Davis-Bacon Act or 29 CFR 5.12(a)(1).

- (2) No part of this contract shall be subcontracted to any person or firm ineligible for award of a United States Government contract by virtue of section 3(a) of the Davis-Bacon Act or 29 CFR 5.12(a)(1).
  - (3) The penalty for making false statements is prescribed in the U. S. Criminal Code, 18 U.S.C. 1001.
- (j) Contract Work Hours and Safety Standards Act. As used in this paragraph, the terms "laborers" and "mechanics" include watchmen and guards.
    - (1) Overtime requirements. No contractor or subcontractor contracting for any part of the contract work which may require or involve the employment of laborers or mechanics, including watchmen and guards, shall require or permit any such laborer or mechanic in any workweek in which the individual is employed on such work to work in excess of 40 hours in such workweek unless such laborer or mechanic receives compensation at a rate not less than one and one-half times the basic rate of pay for all hours worked in excess of 40 hours in such workweek.
    - (2) Violation; liability for unpaid wages; liquidated damages. In the event of any violation of the provisions set forth in subparagraph (j)(1) of this clause, the Contractor and any subcontractor responsible therefor shall be liable for the unpaid wages. In addition, such Contractor and subcontractor shall be liable to the United States (in the case of work done under contract for the District of Columbia or a territory, to such District or to such territory), for liquidated damages. Such liquidated damages shall be computed with respect to each individual laborer or mechanic (including watchmen and guards) employed in violation of the provisions set forth in subparagraph (j)(1) of this clause, in the sum of \$10 for each calendar day on which such individual was required or permitted to work in excess of the standard workweek of 40 hours without payment of the overtime wages required by provisions set forth in subparagraph (j)(1) of this clause.
    - (3) Withholding for unpaid wages and liquidated damages. HUD or its designee shall upon its own action or upon written request of an authorized representative of the Department of Labor withhold or cause to be withheld, from any moneys payable on account of work performed by the Contractor or subcontractor under any such contract or any Federal contract with the same prime Contractor, or any other Federally-assisted contract subject to the Contract Work Hours and Safety Standards Act, which is held by the same prime Contractor, such sums as may be determined to be necessary to satisfy any liabilities of such Contractor or subcontractor for unpaid wages and liquidated damages as provided in the provisions set forth in subparagraph (j)(2) of this clause.
  - (k) Subcontracts. The Contractor or subcontractor shall insert in any subcontracts all the provisions contained in this clause, and such other clauses as HUD or its designee may by appropriate instructions require, and also a clause requiring the subcontractors to include these provisions in any lower tier subcontracts. The prime Contractor shall be responsible for the compliance by any subcontractor or lower tier subcontractor with all these provisions.

---

#### 47. Non-Federal Prevailing Wage Rates

- (a) Any prevailing wage rate (including basic hourly rate and any fringe benefits), determined under State or tribal law to be prevailing, with respect to any employee in any trade or position employed under the contract, is inapplicable to the contract and shall not be enforced against the Contractor or any subcontractor, with respect to employees engaged under the contract whenever such non-Federal prevailing wage rate exceeds:
  - (1) The applicable wage rate determined by the Secretary of Labor pursuant to the Davis-Bacon Act (40 U.S.C. 3141 et seq.) to be prevailing in the locality with respect to such trade;
- (b) An applicable apprentice wage rate based thereon specified in an apprenticeship program registered with the U.S. Department of Labor (DOL) or a DOL-recognized State Apprenticeship Agency; or
- (c) An applicable trainee wage rate based thereon specified in a DOL-certified trainee program.

#### 48. Procurement of Recovered Materials.

- (a) In accordance with Section 6002 of the Solid Waste Disposal Act, as amended by the Resource Conservation and Recovery Act, the Contractor shall procure items designated in guidelines of the Environmental Protection Agency (EPA) at 40 CFR Part 247 that contain the highest percentage of recovered materials practicable, consistent with maintaining a satisfactory level of competition. The Contractor shall procure items designated in the EPA guidelines that contain the highest percentage of recovered materials practicable unless the Contractor determines that such items: (1) are not reasonably available in a reasonable period of time; (2) fail to meet reasonable performance standards, which shall be determined on the basis of the guidelines of the National Institute of Standards and Technology, if applicable to the item; or (3) are only available at an unreasonable price.
- (b) Paragraph (a) of this clause shall apply to items purchased under this contract where: (1) the Contractor purchases in excess of \$10,000 of the item under this contract; or (2) during the preceding Federal fiscal year, the Contractor: (i) purchased any amount of the items for use under a contract that was funded with Federal appropriations and was with a Federal agency or a State agency or agency of a political subdivision of a State; and (ii) purchased a total of in excess of \$10,000 of the item both under and outside that contract.

# DISCLOSURE OF LOBBYING ACTIVITIES

Complete this form to disclose lobbying activities pursuant to 31 U.S.C. 1352

Approved by OMB

0348-0046

(See reverse for public burden disclosure.)

<b>1. Type of Federal Action:</b> <input type="checkbox"/> a. contract <input type="checkbox"/> b. grant <input type="checkbox"/> c. cooperative agreement <input type="checkbox"/> d. loan <input type="checkbox"/> e. loan guarantee <input type="checkbox"/> f. loan insurance	<b>2. Status of Federal Action:</b> <input type="checkbox"/> a. bid/offer/application <input type="checkbox"/> b. initial award <input type="checkbox"/> c. post-award	<b>3. Report Type:</b> <input type="checkbox"/> a. initial filing <input type="checkbox"/> b. material change <b>For Material Change Only:</b> year _____ quarter _____ date of last report _____
<b>4. Name and Address of Reporting Entity:</b> <input type="checkbox"/> Prime <input type="checkbox"/> Subawardee Tier _____, <i>if known</i> :  <b>Congressional District, if known:</b>	<b>5. If Reporting Entity in No. 4 is a Subawardee, Enter Name and Address of Prime:</b>   <b>Congressional District, if known:</b>	
<b>6. Federal Department/Agency:</b>	<b>7. Federal Program Name/Description:</b>  CFDA Number, <i>if applicable</i> : _____	
<b>8. Federal Action Number, if known:</b>	<b>9. Award Amount, if known:</b> \$ _____	
<b>10. a. Name and Address of Lobbying Registrant</b> <i>(if individual, last name, first name, MI):</i>	<b>b. Individuals Performing Services</b> <i>(including address if different from No. 10a)</i> <i>(last name, first name, MI):</i>	
<b>11.</b> Information requested through this form is authorized by title 31 U.S.C. section 1352. This disclosure of lobbying activities is a material representation of fact upon which reliance was placed by the tier above when this transaction was made or entered into. This disclosure is required pursuant to 31 U.S.C. 1352. This information will be available for public inspection. Any person who fails to file the required disclosure shall be subject to a civil penalty of not less than \$10,000 and not more than \$100,000 for each such failure.	Signature: _____ Print Name: _____ Title: _____ Telephone No.: _____ Date: _____	
<b>Federal Use Only:</b>		Authorized for Local Reproduction Standard Form LLL (Rev. 7-97)



## INSTRUCTIONS FOR COMPLETION OF SF-LLL, DISCLOSURE OF LOBBYING ACTIVITIES

This disclosure form shall be completed by the reporting entity, whether subawardee or prime Federal recipient, at the initiation or receipt of a covered Federal action, or a material change to a previous filing, pursuant to title 31 U.S.C. section 1352. The filing of a form is required for each payment or agreement to make payment to any lobbying entity for influencing or attempting to influence an officer or employee of any agency, a Member of Congress, an officer or employee of Congress, or an employee of a Member of Congress in connection with a covered Federal action. Complete all items that apply for both the initial filing and material change report. Refer to the implementing guidance published by the Office of Management and Budget for additional information.

1. Identify the type of covered Federal action for which lobbying activity is and/or has been secured to influence the outcome of a covered Federal action.
2. Identify the status of the covered Federal action.
3. Identify the appropriate classification of this report. If this is a followup report caused by a material change to the information previously reported, enter the year and quarter in which the change occurred. Enter the date of the last previously submitted report by this reporting entity for this covered Federal action.
4. Enter the full name, address, city, State and zip code of the reporting entity. Include Congressional District, if known. Check the appropriate classification of the reporting entity that designates if it is, or expects to be, a prime or subaward recipient. Identify the tier of the subawardee, e.g., the first subawardee of the prime is the 1st tier. Subawards include but are not limited to subcontracts, subgrants and contract awards under grants.
5. If the organization filing the report in item 4 checks "Subawardee," then enter the full name, address, city, State and zip code of the prime Federal recipient. Include Congressional District, if known.
6. Enter the name of the Federal agency making the award or loan commitment. Include at least one organizational level below agency name, if known. For example, Department of Transportation, United States Coast Guard.
7. Enter the Federal program name or description for the covered Federal action (item 1). If known, enter the full Catalog of Federal Domestic Assistance (CFDA) number for grants, cooperative agreements, loans, and loan commitments.
8. Enter the most appropriate Federal identifying number available for the Federal action identified in item 1 (e.g., Request for Proposal (RFP) number; Invitation for Bid (IFB) number; grant announcement number; the contract, grant, or loan award number; the application/proposal control number assigned by the Federal agency). Include prefixes, e.g., "RFP-DE-90-001."
9. For a covered Federal action where there has been an award or loan commitment by the Federal agency, enter the Federal amount of the award/loan commitment for the prime entity identified in item 4 or 5.
10. (a) Enter the full name, address, city, State and zip code of the lobbying registrant under the Lobbying Disclosure Act of 1995 engaged by the reporting entity identified in item 4 to influence the covered Federal action.  
  
(b) Enter the full names of the individual(s) performing services, and include full address if different from 10 (a). Enter Last Name, First Name, and Middle Initial (MI).
11. The certifying official shall sign and date the form, print his/her name, title, and telephone number.

According to the Paperwork Reduction Act, as amended, no persons are required to respond to a collection of information unless it displays a valid OMB Control Number. The valid OMB control number for this information collection is OMB No. 0348-0046. Public reporting burden for this collection of information is estimated to average 10 minutes per response, including time for reviewing instructions, searching existing data sources, gathering and maintaining the data needed, and completing and reviewing the collection of information. Send comments regarding the burden estimate or any other aspect of this collection of information, including suggestions for reducing this burden, to the Office of Management and Budget, Paperwork Reduction Project (0348-0046), Washington, DC 20503.

## NON-COLLUSION AFFIDAVIT OF CONTRACTOR

\_\_\_\_\_ does hereby state:  
(name)

(1) S/He is the \_\_\_\_\_ of  
(owner, partner, officer, or representative),  
\_\_\_\_\_, hereinafter referred to as Contractor.  
(business name)

(2) S/He is fully knowledgeable of the preparation and contents of Subcontractor's proposals which were submitted to (Contractor);  
\_\_\_\_\_, for specific work required in  
connection with a Home Forward project titled \_\_\_\_\_  
and located at : \_\_\_\_\_

(3) Said Contractor's proposal is genuine and is not a collusive or sham proposal;

(4) Neither the Contractor nor any of its officers, partners, owners, agents, representatives, employees, or parties in interest, including myself, has in any way colluded, conspired, connived, or agreed, directly or indirectly, with any other bidder, firm, or person to submit a collusive or sham proposal in connection with such contract or to refrain from submitting a proposal in connection with such contract, or has in any manner, directly or indirectly, sought by unlawful agreement or connivance with any other bidder, firm, or person to fix the price or prices in said Contractor's Proposal, or to fix any overhead, profit, or cost element of the price or prices in said Contractor's Proposal, or to secure through collusion, conspiracy, connivance, or unlawful agreement any advantage against Home Forward, or any person interested in the proposed Contract; and

(5) The price or prices quoted in the Contractor's Proposal are fair and proper and are not tainted by any collusion, conspiracy, connivance, or unlawful agreement on the part of the Bidder or any of its agents, representatives, owners, employees, or parties in interest, including myself.

Signed: \_\_\_\_\_

Title: \_\_\_\_\_

Date: \_\_\_\_\_

Witnessed by: \_\_\_\_\_

# Certification for a Drug-Free Workplace

U.S. Department of Housing and Urban Development

Applicant Name

Program/Activity Receiving Federal Grant Funding

Acting on behalf of the above named Applicant as its Authorized Official, I make the following certifications and agreements to the Department of Housing and Urban Development (HUD) regarding the sites listed below:

I certify that the above named Applicant will or will continue to provide a drug-free workplace by:

a. Publishing a statement notifying employees that the unlawful manufacture, distribution, dispensing, possession, or use of a controlled substance is prohibited in the Applicant's workplace and specifying the actions that will be taken against employees for violation of such prohibition.

b. Establishing an on-going drug-free awareness program to inform employees ---

(1) The dangers of drug abuse in the workplace;

(2) The Applicant's policy of maintaining a drug-free workplace;

(3) Any available drug counseling, rehabilitation, and employee assistance programs; and

(4) The penalties that may be imposed upon employees for drug abuse violations occurring in the workplace.

c. Making it a requirement that each employee to be engaged in the performance of the grant be given a copy of the statement required by paragraph a.;

d. Notifying the employee in the statement required by paragraph a. that, as a condition of employment under the grant, the employee will ---

(1) Abide by the terms of the statement; and

(2) Notify the employer in writing of his or her conviction for a violation of a criminal drug statute occurring in the workplace no later than five calendar days after such conviction;

e. Notifying the agency in writing, within ten calendar days after receiving notice under subparagraph d.(2) from an employee or otherwise receiving actual notice of such conviction. Employers of convicted employees must provide notice, including position title, to every grant officer or other designee on whose grant activity the convicted employee was working, unless the Federalagency has designated a central point for the receipt of such notices. Notice shall include the identification number(s) of each affected grant;

f. Taking one of the following actions, within 30 calendar days of receiving notice under subparagraph d.(2), with respect to any employee who is so convicted ---

(1) Taking appropriate personnel action against such an employee, up to and including termination, consistent with the requirements of the Rehabilitation Act of 1973, as amended; or

(2) Requiring such employee to participate satisfactorily in a drug abuse assistance or rehabilitation program approved for such purposes by a Federal, State, or local health, law enforcement, or other appropriate agency;

g. Making a good faith effort to continue to maintain a drug-free workplace through implementation of paragraphs a. thru f.

**2. Sites for Work Performance.** The Applicant shall list (on separate pages) the site(s) for the performance of work done in connection with the HUD funding of the program/activity shown above: Place of Performance shall include the street address, city, county, State, and zip code. Identify each sheet with the Applicant name and address and the program/activity receiving grant funding.)

Check here  if there are workplaces on file that are not identified on the attached sheets.

I hereby certify that all the information stated herein, as well as any information provided in the accompaniment herewith, is true and accurate.

**Warning:** HUD will prosecute false claims and statements. Conviction may result in criminal and/or civil penalties.

(18 U.S.C. 1001, 1010, 1012; 31 U.S.C. 3729, 3802)

Name of Authorized Official

Title

Signature

Date

X

SWORN STATEMENT PURSUANT TO SECTION 287.133(3)(a),  
FLORIDA STATUTES, ON PUBLIC ENTITY CRIMES

THIS FORM MUST BE SIGNED AND SWORN TO IN THE PRESENCE OF A NOTARY PUBLIC OR OTHER OFFICIAL AUTHORIZED TO AND MINISTER OATHS.

1. This sworn statement is submitted to \_\_\_\_\_  
[print name of the public entity]  
by \_\_\_\_\_  
[print individual's name and title]  
for \_\_\_\_\_  
[print name of entity submitting sworn statement]

whose business address is

\_\_\_\_\_  
\_\_\_\_\_

and (if applicable) its Federal Employer Identification Number (FEIN) is \_\_\_\_\_

(If the entity has no FEIN, include the Social Security Number of the individual signing this sworn

statement: \_\_\_\_\_.)

2. I understand that a “public entity crime” as defined in Paragraph 287.133(1)(g), Florida Statutes, means a violation of any state or federal law by a person with respect to and directly related to the transaction of business with any public entity or with an agency or political subdivision of any other state or of the United States, including, but not limited to, any bid or contract for goods or services to be provided to any public entity or an agency or political subdivision of any other state or of the United States and involving antitrust, fraud, theft, bribery, collusion, racketeering, conspiracy, or material misrepresentation.
3. I understand that “convicted” or “conviction” as defined in Paragraph 287.133(1)(b), Florida Statutes, means a finding of guilt or a conviction of a public entity crime, with or without an adjudication of guilt, in any federal or state trial court of record relating to charges brought by indictment or information after July 1, 1989, as a result of a jury verdict, nonjury trial, or entry of a plea of guilty or nolo contendere.
4. I understand that an “affiliate” as defined in Paragraph 287.133(1)(a), Florida Statutes, means:
1. A predecessor or successor of a person convicted of a public entity crime; or
  2. An entity under the control of any natural person who is active in the management of the entity and who has been convicted of a public entity crime. The term “affiliate” includes those officers, directors, executives, partners, shareholders, employees, members, and agents who are active in the management of an affiliate. The ownership by one person of shares constituting a controlling interest in another person, or a pooling of equipment or income among persons when not for fair market value under an arm’s length agreement, shall be a prima facie case that one person controls another person. A person who knowingly enters into a joint venture with a person who has been convicted of a public entity crime in Florida during the preceding 36 months shall be considered an affiliate.
5. I understand that a “person” as defined in Paragraph 287.133(1)(e), Florida Statutes, means any natural person or entity organized under the laws of any state or of the United States with the legal power to enter into a binding contract and which bids or applies to bid on contracts for the provision of goods or services let by a public entity, or which otherwise transacts or applies to transact business with a public entity. The term “person” includes those officers, directors, executives, partners, shareholders, employees, members, and agents who are active in management of an entity.

6. Based on information and belief, the statement which I have marked below is true in relation to the entity submitting this sworn statement. [Indicate which statement applies]

\_\_\_\_\_ Neither the entity submitting this sworn statement, nor any of its officers, directors, executives, partners, shareholders, employees, members, or agents who are active in the management of the entity, nor any affiliate of the entity has been charged with and convicted of a public entity crime subsequent to July 1, 1989.

\_\_\_\_\_ The entity submitting this sworn statement, or one or more of its officers, directors, executives, partners, shareholders, employees, members, or agents who are active in the management of the entity, or an affiliate of the entity has been charged with and convicted of a public entity crime subsequent to July 1, 1989.

\_\_\_\_\_ The entity submitting this sworn statement, or one or more of its officers, directors, executives, partners, shareholders, employees, members, or agents who are active in the management of the entity or an affiliate of the entity has been charged with and convicted of a public entity crime subsequent to July 1, 1989. However, there has been a subsequent proceeding before a Hearing Officer of the State of Florida, Division of Administrative hearings and the Final Order entered by the Hearing Officer determined that it was not in the public interest to place the entity submitting this sworn statement on the convicted vendor list. (attach a copy of the final order)

I UNDERSTAND THAT THE SUBMISSION OF THE FORM TO THE CONTRACTING OFFICER FOR THE PUBLIC ENTITY IDENTIFIED IN PARAGRAPH 1 (ONE) ABOVE IS FOR THAT PUBLIC ENTITY ONLY AND, THAT THIS FORM IS VALID THROUGH DECEMBER 31 OF THE CALENDAR YEAR IN WHICH IT IS FILED. I ALSO UNDERSTAND THAT I AM REQUIRED TO INFORM THE PUBLIC ENTITY PRIOR TO ENTERING INTO A CONTRACT IN EXCESS OF THE THRESHOLD AMOUNT PROVIDED IN SECTION 287.017, FLORIDA STATUTES FOR CATEGORY TWO OF ANY CHANGE IN THE INFORMATION CONTAINED IN THIS FORM.

\_\_\_\_\_  
[signature]

Sworn to and subscribed before me this \_\_\_\_\_ day of \_\_\_\_\_, 20\_\_\_\_\_.

Personally known \_\_\_\_\_

Or Produced identification \_\_\_\_\_ Notary Public – State of \_\_\_\_\_

\_\_\_\_\_  
(Type of Identification) My commission expires \_\_\_\_\_

\_\_\_\_\_  
(Printed, typed or stamped  
commission name of notary public)

**Equal Employment  
Opportunity Certification**  
Excerpt From 41 CFR §60-1.4(b)

**U.S. Department of Housing  
and Urban Development**  
Office of Housing  
Federal Housing Commissioner

**Department of Veterans Affairs**  
OMB Control No. 2502-0029  
(exp. 9/30/2016)

The applicant hereby agrees that it will incorporate or cause to be incorporated into any contract for construction work, or modification thereof, as defined in the regulations of the Secretary of Labor at 41 CFR Chapter 60, which is paid for in whole or in part with funds obtained from the Federal Government or borrowed on the credit of the Federal Government pursuant to a grant, contract, loan insurance, or guarantee, or undertaken pursuant to any Federal program involving such grant, contract, loan, insurance, or guarantee, the following equal opportunity clause:

During the performance of this contract, the contractor agrees as follows:

- (1) The contractor will not discriminate against any employee or applicant for employment because of race, color, religion, sex, or national origin. The contractor will take affirmative action to ensure that applicants are employed, and that employees are treated during employment without regard to their race, color, religion, sex, or national origin, such action shall include, but not be limited to the following: Employment, upgrading, demotion, or transfer; recruitment or recruitment advertising; layoff or termination; rates of pay or other forms of compensation; and selection for training, including apprenticeship. The contractor agrees to post in conspicuous places, available to employees and applicants for employment, notices to be provided setting forth the provisions of this nondiscrimination clause.
- (2) The contractor will, in all solicitations or advertisements for employees placed by or on behalf of the contractor, state that all qualified applicants will receive considerations for employment without regard to race, color, religion, sex, or national origin.
- (3) The contractor will send to each labor union or representative of workers with which it has a collective bargaining agreement or other contract or understanding, a notice to be provided advising the said labor union or workers' representatives of the contractor's commitments under this section, and shall post copies of the notice in conspicuous places available to employees and applicants for employment.
- (4) The contractor will comply with all provisions of Executive Order 11246 of September 24, 1965, and of the rules, regulations and relevant orders of the Secretary of Labor.
- (5) The contractor will furnish all information and reports required by Executive Order 11246 of September 24, 1965, and by rules, regulations, and orders of the Secretary of Labor, or pursuant thereto, and will permit access to its books, records, and accounts by the administering agency and the Secretary of Labor for purposes of investigation to ascertain compliance with such rules, regulations, and orders.

- (6) In the event of the contractor's noncompliance with the nondiscrimination clauses of this contract or with any of the said rules, regulations, or orders, this contract may be canceled, terminated, or suspended in whole or in part and the contractor may be declared ineligible for further Government contracts or federally assisted construction contracts in accordance with procedures authorized in Executive Order 11246 of September 24, 1965, and such other sanctions may be imposed and remedies invoked as provided in Executive Order 11246 of September 24, 1965, or by rule, regulation, or order of the Secretary of Labor, or as otherwise provided by law.
- (7) The contractor will include the portion of the sentence immediately preceding paragraph (1) and the provisions of paragraphs (1) through (7) in every subcontract or purchase order unless exempted by rules, regulations, or orders of the Secretary of Labor issued pursuant to section 204 of Executive Order 11246 of September 24, 1965, so that such provisions will be binding upon each subcontractor or vendor. The contractor will take such action with respect to any subcontract or purchase order as the administering agency may direct as a means of enforcing such provisions, including sanctions for noncompliance: **Provided, however,** That in the event a contractor becomes involved in, or is threatened with, litigation with a subcontractor or vendor as a result of such direction by the administering agency the contractor may request the United States to enter into such litigation to protect the interests of the United States.

The applicant further agrees that it will be bound by the above equal opportunity clause with respect to its own employment practices when it participates in federally assisted construction work:

**Provided,** That if the applicant so participating is a State or local government, the above equal opportunity clause is not applicable to any agency, instrumentality or subdivision of such government which does not participate in work on or under the contract.

The applicant agrees that it will assist and cooperate actively with the administering agency and the Secretary of Labor in obtaining the compliance of contractors and subcontractors with the equal opportunity clause and the rules, regulations, and relevant orders of the Secretary of Labor, that it will furnish the administering agency and the Secretary of Labor such information as they may require for the supervision of such compliance, and that it will otherwise assist the administering agency in the discharge of the agency's primary responsibility for securing compliance.

The applicant further agrees that it will refrain from entering into any contract or contract modification subject to Executive Order 11246 of September 24, 1965, with a contractor debarred from, or who has not demonstrated eligibility for, Government contracts and Federally-assisted construction contracts pursuant to the Executive order and will carry out such sanctions and penalties for violation of the equal opportunity clause as may be imposed

Firm Name and Address	By
	Title

upon contractors and subcontractors by the administering agency or the Secretary of Labor pursuant to Part II, Subpart D of the Executive order. In addition, the applicant agrees that if it fails or refuses to comply with these undertakings, the administering agency may take any or all of the following actions: Cancel, terminate, or suspend in whole or in part this grant (contract, loan, insurance, guarantee); refrain from extending any further assistance to the applicant under the program with respect to which the failure or refund occurred until satisfactory assurance of future compliance has been received from such applicant; and refer the case to the Department of Justice for appropriate legal proceedings.

#### **Excerpt from HUD Regulations**

200.410 Definition of term "applicant".

- (a) In multifamily housing transactions where controls over the mortgagor are exercised by the Commissioner either through the ownership of corporate stock or under the provisions of a regulatory agreement, the term "applicant" as used in this subpart shall mean the mortgagor.
- (b) In transactions other than those specified in paragraph(a) of this section, the term "applicant" as used in this subpart shall mean the builder, dealer or contractor performing the construction, repair or rehabilitation work for the mortgagor or other borrower.

200.420 Equal Opportunity Clause to be included in contracts and subcontracts.

- (a) The following equal opportunity clause shall be included in each contract and subcontract which is not exempt:

During the performance of this contract, the contractor agrees as follows:

- (1) The contractor will not discriminate against any employee or applicant for employment because of race, creed, color, or national origin. The contractor will take affirmative action to ensure that applicants are employed, and that employees are treated during employment without regard to their race, creed, color, or national origin. Such action shall include, but not be limited to the following: employment, upgrading, demotion or transfer; recruitment or recruitment advertising; layoff or termination; rates of pay or other forms of compensation; and selection for training, including apprenticeship. The contractor agrees to post in conspicuous places, available to employees and applicants for employment, notices to be provided setting forth the provisions of the nondiscrimination clause.

- (2) The contractor will in all solicitations or advertisements for employees placed by or on behalf of the contractor, state that all qualified applicants will receive consideration for employment without regard race, creed, color, or national origin.

- (3) The contractor will send to each labor union or representative of workers with which he has a collective bargaining agreement or other contract or understanding, a notice, to be provided, advising the said labor union or workers' representative of the contractor's commitments under this section, and shall post copies of the notices in conspicuous places available to employees and applicants for employment.

- (4) The contractor will comply with all provisions of Executive Order 10925 of March 6 1961, as amended, and of the regulations, and relevant orders of the President's Committee on Equal Employment Opportunity created thereby.

- (5) The contractor will furnish all information and reports required by Executive Order 10925 of March 6, 1961, as amended, and by the regulations, and orders of the said Committee, or pursuant thereto, and will permit access to his books, records, and accounts by HUD and the Committee for purposes of investigation to ascertain compliance with such regulations, and orders.

- (6) In the event of the contractor's non-compliance with the nondiscrimination clause of this contract or with any of the said regulations, or orders, this contract may be cancelled, terminated or suspended in whole or in part and the contractor may be declared ineligible for further Government contracts or Federally-assisted construction contracts in accordance with procedures authorized in Executive Order 10925 of March 6, 1961, as amended, and such other sanctions may be imposed and remedies invoked provided in the said Executive Order or by regulations, or order of the President's Committee on Equal Employment Opportunity, or as otherwise provided by law.

- (7) The contractor will include the provisions of Paragraphs(1) through (7) in every subcontract or purchase order unless exempted by regulations, or orders of the President's Committee on Equal Employment Opportunity issued pursuant to Section 303 of Executive Order 10925 of March 6, 1961, as amended, so that such provisions will be binding upon each subcontractor or vendor. The contractor will take such action with respect to any subcontract or purchase orders as HUD may direct as a means of enforcing such provisions, including sanctions for noncompliance: Provided, however, that in the event the contractor becomes involved in, or is threatened with, litigation with a subcontractor or vendor as a result of such direction by HUD, the contractor may request the United States to enter into such litigation to protect the interests of the United States.

- (b) Except in subcontracts for the performance of construction work at the site of construction, the clause is not required to be inserted in subcontracts below the second tier. Subcontracts may incorporate by reference to the equal opportunity clause.

200.425 Modification in and exemptions from the regulations in this subpart.

- (a) The following transactions and contracts are exempt from the regulations in this subpart:

- (1) Loans, mortgages, contracts and subcontracts not exceeding \$10,000.

- (2) Contract and subcontracts not exceeding \$100,000 for standard commercial supplies or raw material;

- (3) Contracts and subcontracts under which work is to be or has been performed outside the United States and where no recruitment of workers within the United States is involved. To the extent that work pursuant to such contracts is done within the United States, the equal opportunity clause shall be applicable;

- (4) Contracts for the sale of Government property where no appreciable amount of work is involved; and

- (5) Contracts and subcontracts for an indefinite quantity which are not to extend for more than one year if the purchaser determines that the amounts to be ordered under any such contract or subcontract are not reasonably expected to exceed \$100,000 in the case of contracts or subcontracts for standard commercial supplies and raw materials, or \$10,000 in the case of all other contracts and subcontracts.



## **SECTION 3**

The work to be performed under this contract is subject to the requirements of Section 3 of the Housing and Urban Development Act of 1968, as amended, 12 U.S.C. 1701u (Section 3).

**Please visit The Housing Authority of the City of Fort Myers (HACFM) website by clicking on the following link to become educated with the HACFM Plan in its entirety.**

<http://hacfm.org/web/page.asp?urh=Section3>

---

**THE FOLLOWING PACKAGE INCLUDES VARIOUS FORMS THAT MUST BE RETURNED WITH YOUR PROPOSAL.**

**Table of Contents:**

Attachment I	HUD CFR Part 135 Section 3 Regulations
Attachment II	Section 3 Special Conditions
Attachment III	Part IV Definitions
Attachment IV	Section 3 Opportunities Plan (pages 1-6)
Attachment V	Section 3 New Hire Compliance Report (pages 1 – 6)

**Note: Attachment IV and V must be returned in their entirety with the proposal package.**



# ATTACHMENT I

## SECTION 3 CLAUSE

*This contract is subject to the following conditions under Section 3 of the Housing and Urban Development Act of 1968, as amended, 12 U.S.C. 1701u (Section 3).*

- A. The work to be performed under this contract is subject to the requirements of Section 3 of the Housing and Urban Development Act of 1968, as amended, 12 U.S.C. 1701u (Section 3). The purpose of Section 3 is to ensure that employment and other economic opportunities generated by HUD assistance or HUD-assisted projects covered by Section 3, shall, to the greatest extent feasible, be directed to low and very low-income persons, particularly persons who are recipients of HUD assistance for housing.
- B. The parties to this contract agree to comply with HUD's regulations in 24 CFR Part 135, which implement Section 3. As evidenced by their execution of this contract, the parties to this contract certify that they are under no contractual or other impediment that would prevent them from complying with the Part 135 regulations.
- C. The contractor agrees to send to each labor organization or representative of workers with which the contractor has a collective bargaining agreement or other understanding, if any, a notice advising the labor or organization or workers' representative of the contractor's commitments under this Section 3 clause, and will post copies of the notice in conspicuous places at the work site where both employees and applicants for training and employment positions can see the notice. The notice shall describe the Section 3 preference, shall set forth minimum number and job titles subject to hire, availability of apprenticeship and training positions, the qualifications for each; and the name and location of the person(s) taking applications for each of the positions; and the anticipated date the work shall begin.
- D. The contractor agrees to include this Section 3 clause in every subcontract subject to compliance with regulations in 24 CFR Part 135, and agrees to take appropriate action, as provided in an applicable provision of the subcontract or in this Section 3 clause, upon finding that the subcontractor is in violation of the regulations in 24 CFR Part 135. The contractor will not subcontract with any subcontractor where the contractor has notice or knowledge that the subcontractor has been found in violation of the regulations in 24 CFR Part 135.
- E. The contractor will certify that any vacant employment positions, including training positions that are filled (1) after the contractor is selected but before the contract is executed, and (2) with persons other than those to whom the regulations of 24 CFR Part 135 require employment opportunities to be directed, were not filled to circumvent the contractor's obligations under 24 CFR Part 135.
- F. Noncompliance with HUD's regulations in 24 CFR Part 135 may result in sanctions, termination of this contract for default, and debarment or suspension from future HUD assisted contracts.
- G. With respect to work performed in connection with Section 3 covered Indian housing assistance, Section 7(b) of the Indian Self-Determination and Education Assistance Act (25 U.S.C. 450e) also applies to the work to be performed under this contract. Section 7(b) requires that to the greatest extent feasible (preference and opportunities for training and employment shall be given to Indians, and (ii) preference in the award of contracts and subcontracts shall be given to Indian organizations and Indian-owned Economic Enterprise. Parties to this contract that are subject to the provisions of Section 3 and Section 7(b) agree to comply with Section 3 to the maximum extent feasible, but not in derogation of compliance with Section 7(b).

**I the undersigned contractor have read the above Section 3 Clause will comply with HUD, 24 CFR Part 135 – Section 3 Regulations.**

\_\_\_\_\_  
Signature

\_\_\_\_\_  
Date

\_\_\_\_\_  
Printed Name

\_\_\_\_\_  
Title



## **ATTACHMENT II**

### **SECTION 3 SPECIAL CONDITIONS**

HACFM has initiated efforts to enhance resident hiring on construction related contracts. These initiatives are designed to set the requirements for resident hiring and developing and/or strengthening administrative procedures for facilitating contractors' hiring of HACFM residents and other low income and/or very low-income residents residing in the section 3 area.

#### **1. Procurement Documents**

- Each bidder must include a Section 3 Opportunities Plan which indicates its commitment to meet HACFM resident hiring requirements.
- If a bidder fails to submit a Section 3 Opportunities Plan and the related data along with the bid, such bid will be declared as "non-responsive".
- For Invitations for Bids ("IFB") where awards are made to the most responsive and responsible bidder, the bidder's commitment to satisfy HACFM resident hiring requirements will be a factor used in determining whether the bidder is "responsive".
- For RFQ's, RFP's and IFB's, contractors shall be required to detail the cost of the bid or proposal by separately categorizing contract cost by labor (person hours and dollar amounts).

#### **2. Enforcement**

- To enforce the decision-making process pertaining to determining applicable percentages for resident hiring, enforcement strategies are set forth below.
- During the post award or pre-construction meeting, the objective shall be to impart critical Section 3 information to the contractor prior to commencement of the work/project. The following contract requirements shall be discussed in detail (Non-construction contracts do not require Davis-Bacon compliance):
  - Davis-Bacon Wage Requirements
  - Minority and Women Owned Business Participation requirements
  - Section 3 Program requirements

HACFM representatives will require the contractor to certify its understanding of the terms and conditions of the contract as they pertain to Davis-Bacon, Section 3 hiring and Minority and Women Owned Business participation.

#### **3. Monitoring and Enforcement Authority and Responsibility**

The function of monitoring and enforcing Section 3 Compliance and hiring will be carried out by the Section 3 Coordinator in coordination with the Real Estate Development Office



## **ATTACHMENT III**

**Business Concern** – a business entity formed in accordance with State law, and which is licensed under State, county or municipal law to engage in the type of business activity for which it was formed.

**Contractor** – any entity which contracts for the performance of work generated by the expenditure of Section 3 covered assistance, or performing work in connection with a Section 3 covered project.

**Employment Opportunities Generated by Section 3 Covered Assistance** – all employment opportunities generated by the expenditure of Section 3 covered public assistance (i.e., operating assistance, development assistance and modernization assistance, (as described in 24 CFR Section 135.3 (a) (1)). With respect to Section 3 covered housing and community development assistance, this term means all employment opportunities arising in connection with Section 3 covered projects (as described in Section 135.3 (a) (2)), including management and administrative jobs. Management and administrative jobs include architectural, engineering or related professional services required to prepare plans, drawings, specifications, or work write-ups; and jobs directly related to administrative support of these activities, e.g., construction manager, relocation specialist, payroll clerk, etc.

**Housing Authority** (HA) – Public Housing Agency.

**Housing Development** – low-income housing owned, developed, or operated by public housing agencies in accordance with HUD’s public housing program regulations codified in 24 CFR Chapter IX.

**HUD Youthbuild Programs** – programs that receive assistance under subtitle D of Title IV of the National Affordable Housing Act, as amended by the Housing and Community Development Act of 1992 (42 U.S.C. 12899), and provide disadvantaged youth with opportunities for employment, education, leadership development, and training in the construction or rehabilitation of housing for homeless individuals and members of low- and very low-income families.

**Low-income person** – families (including single persons) whose incomes do not exceed 80 per centum of the median income for the area, as determined by the Secretary, with adjustments for smaller and larger families, except that the Secretary may establish income ceilings higher or lower than 80 per centum of the median for the area on the basis of the Secretary’s findings that such variations are necessary because of prevailing levels of construction costs or unusually high or low-income families.

**Metropolitan Area** – a metropolitan statistical area (MSA), as established by the Office of Management and Budget.



**New Hires** – full-time employees for permanent, temporary or seasonal employment opportunities.

**Recipient** – any entity which receives Section 3 covered assistance, directly from HUD or from another recipient and includes, but is not limited to, any State unit of local government, PHA, or other public body, public or private nonprofit organization, private agency or institution, mortgagor, developer, limited dividend sponsor, builder, property manager, community housing development organization, resident management corporation, resident council, or cooperative association. Recipient also includes any successor, assignee or transferee of any such entity, but does not include any ultimate beneficiary under the HUD program to which Section 3 applies and does not include contractors.

**Section 3** –Section 3 of the Housing and Urban Development Act of 1968, as amended (12 U.S.C. 1701u).

**Section 3 Business Concern** – a business concern,

- 1) That is 51 percent or more owned by Section 3 resident: or
- 2) Whose permanent, full-time employees include persons, at least 30 percent of whom are currently Section 3 residents, or within three years of the date of first employment with the business concern were Section 3 residents; or
- 3) That provides evidence of a commitment to subcontract in excess of 25 percent of the dollar award of all subcontractors to be awarded to business concerns that meet the qualifications set forth in paragraphs 1 or 2 above.

**Section 3 Covered Assistance** –

- 1) Public housing development assistance provided pursuant to Section 5 of the 1937 Act;
- 2) Public housing operating assistance provided pursuant to Section 9 of the 1937 Act;
- 3) Public housing modernization assistance provided pursuant to Section 14 of the 1937 Act; 4) Assistance provided under any HUD housing or community development program that is expended for work arising in connection with housing rehabilitation, construction, or other public construction project (which includes other buildings or improvements, regardless of ownership).

Section 3 Clause – the contract provisions set forth in 24 CFR Section 135.38.

**Section 3 Covered Contracts** – a contract or subcontract (including a professional service contract) awarded by a recipient or contractor for work generated by the expenditure of Section 3 covered assistance, or for work arising in connection with a Section 3 covered project. Section 3 covered contracts do not include contracts awarded under HUD's procurement program, which are governed by the Federal Acquisition Regulation (FAR). Section 3 covered contracts also do not include contracts for the purchase of supplies and materials. However, whenever a contract for materials includes the installation of the materials, the contract constitutes a Section 3 covered contract.



**Section 3 Covered Project** - the construction, reconstruction, conversion or rehabilitation of housing (including reduction and abatement of lead-based paint hazards), other public construction which includes buildings or improvements (regardless of ownership) assisted with housing or community development assistance.

**Section 3 Resident** – a public housing resident or an individual who resides in the metropolitan area or non-metropolitan County in which the Section 3 covered assistance is expended and who is considered to be a low to very low-income person.

**Subcontractor** – any entity (other than a person who is an employee of the contractor) which has a contract with a contractor to undertake a portion of the contractor’s obligation for the performance of work generated by the expenditure of Section 3 covered assistance, or arising in connection with a Section 3 covered project.

**Very low income person** – families (including single persons) whose income do not exceed 50 per centum of the median family income for the area, as determined by the Secretary with adjustments for smaller and larger families, except that the Secretary may establish income ceilings higher or lower than 50 per centum of the median for the area on the basis of the Secretary’s findings that such variations are necessary because of unusually high or low family incomes.



## **ATTACHMENT IV**

### **SECTION 3 OPPORTUNITIES PLAN**

#### **Business Opportunities and Employment Training for Housing Authority of the City of Fort Myers Low Income Public Housing Residents (LIPH) and Low and Very Low Income City of Fort Myers Neighborhood Area Residents (LIAR)**

**PRIME CONTRACTOR'S NAME:** \_\_\_\_\_

**SPECIFICATION OR RFP/IFB/RFQ NUMBER:** \_\_\_\_\_

**SPECIFICATION OR RFP/IFB/RFQ TITLE:** \_\_\_\_\_

The Contractor hereby agrees to comply with all the provisions of Section 3 as set forth in 24 CFR 135.1 et seq. and the HACFM Section 3 Policy and Program requirements. The Contractor hereby submits this document to identify employment opportunities for HACP residents (LIPH) and low and very low income City of Fort Myers neighborhood area residents (LIAR) during the term of the contract between the Contractor and the HACFM.

The preference of HACFM is to ensure that as many HACFM residents as possible are employed. In an effort to further that requirement, HACFM has created a preference tier structure as outlined in the attached Section 3 Policy and Program Manual. Contractors are required to comply with Section 3 by first considering Tier I – Hiring. The Contractor agrees to meet its Section 3 requirement following the Preferential Tier Structure as indicated by the selection below (check one or more tiers below):

**[ ] Tier I – HIRING**

The Contractor affirms that the jobs identified shall be for meaningful employment that may or may not be related to the scope of services covered under Contract/Purchase Order # \_\_\_\_\_. The Contractor has committed to employ \_\_\_\_\_ resident(s) in order to comply with its Section 3 requirements. A prime contractor may satisfy HACFM Resident Hiring Requirements through his/her subcontractors.

**Contact HACFM Real Estate Development Office for resident referrals at 239-344-3232.**

When Tier I is selected, the Contractor shall complete the following table as instructed below:

- (1) Indicate each job title for all phases of this contract
- (2) The number of positions that will be needed in each category
- (3) How many of those positions are currently filled
- (4) The number currently filled by low and very low-income HACFM residents
- (5) The number currently filled by City of Fort Myers neighborhood area residents



(6) How many positions need to be filled

**Indicate your requirement for the number of positions you intend to fill with:**

(7) Low income HACFM Residents (LIPH) and/or

(8) Low and very low income City of Fort Myers Neighborhood Area Residents (LIAR)

**[ ] Tier II – CONTRACTING**

The contractor has identified HACFM resident-owned business(es) or Section 3 business(es) which is/are 51 percent or more owned by Section 3 residents or 30 percent or more of their permanent full-time workforce are Section 3 residents. This will satisfy the contractor's Section 3 requirement covered under Contract/Purchase Order # .

**In a one (1) page letter on your firm's letterhead:**

1) Indicate the requirements, expressed in terms of percentage, of planned contracting dollars for the use of Section 3 business concerns as subcontractors.

2) A statement of the total dollar amount to be contracted, total dollar amount to be contracted to Section 3 business concerns for building trades, and total dollar amount to be contracted to Section 3 business concerns for other than building trades work (maintenance, repair, modernization, and development).

3) A description of the method used to develop the requirements above and the efforts to be undertaken by the contractor to meet those requirements.

**[ ] Tier III - OTHER ECONOMIC OPPORTUNITIES**

Contractors may provide other economic opportunities to train and employ Section 3 residents by incurring the cost of providing skilled training for residents in an amount commensurate with the sliding scale set forth in the Resident Hiring Scale



**SECTION 3 INCOME LIMITS**

**(FY 2009 Income Limits from [www.huduser.org](http://www.huduser.org))**

All residents of public housing developments of the Housing Authority of the City of Fort Myers qualify as Section 3 residents. Additionally, individuals residing in Lee County who meet the income limits set forth below can also qualify for Section 3 status.

**A picture identification and proof of current residency is required.**

**Eligibility Guidelines**

<b>Number in Household</b>	<b>Very low-income (50%)</b>	<b>Low income (80%)</b>
1 person	\$21,250	\$34,000
2 person	\$24,300	\$38,850
3 person	\$27,300	\$43,700
4 person	\$30,350	\$48,550
5 person	\$32,800	\$52,450
6 person	\$35,200	\$56,300
7 person	\$37,650	\$60,200
8 person	\$40,050	\$64,100







## SECTION 3 OPPORTUNITIES PLAN

By signing below, the Contractor hereby agrees to comply with the selected Section 3 requirements indicated above. To the extent that the completion of this form is contingent upon future information, for example price negotiations, request for specific services, etc., the undersigned hereby affirms and agrees to fully adhere to the spirit and intent of the HACFM Section 3 Policy.

Furthermore, the undersigned acknowledges and affirms responsibility for completion and submission of this form PRIOR to the AWARD of a contract from HACFM. Failure to submit this form may jeopardize the responsiveness of your submission.

### Attest/Witness

\_\_\_\_\_

Company Name: \_\_\_\_\_

By: \_\_\_\_\_

Name: \_\_\_\_\_

Title: \_\_\_\_\_

Date: \_\_\_\_\_



**Certification of Receipt and Understanding of the HACFM Section 3  
Plan and Compliance Requirements:**

I \_\_\_\_\_ the \_\_\_\_\_  
(printed Name) (Title)

of \_\_\_\_\_ herby acknowledge  
(Company Name)

receipt and understanding of, and pledge to adhere to, the Section 3 Plan.

Authorized Signature \_\_\_\_\_ Date \_\_\_\_\_



## SECTION 3 NEW HIRE COMPLIANCE REPORT

The US Department of Housing & Urban Development (“HUD”) requires the Housing Authority of the City of Fort Myers to collect information on every person hired in connection with Section 3 projects to ensure HACFM’s compliance with Federal regulations.

As part of HACFM’s Section 3 program your firm is required to report the number of employees hired in connection with a Section 3 Project who are Section 3 Eligible. Complete this form by entering the names and addresses of all new hires and by indicating whether they are Section 3 eligible. For purposes of HACFM, a Section 3 resident is:

1. A public housing resident;
2. An individual who lives within the City of Fort Myers and whose income falls within the guidelines for low or very low income. **See table on page 19.**

**This form must be completed by all firms working on a Section 3 project, defined as a contract that exceeds \$100,000, even if the firm is not a “Section 3 Business.”**

### **INSTRUCTIONS FOR EMPLOYERS:**

1. Enter the name and address of every new employee hired in connection with the Section 3 Project on the following list. (Add additional sheets if necessary).
2. For Employees **NOT HIRED** through HACFM, determine whether each new hire is Section 3 eligible by asking the employee the following questions upon hiring:

**a. Are you a resident of HACFM public housing?**

- YES
- NO

If the answer is “YES,” please skip question “b” and proceed directly to question “c”.

If the answer is “NO,” please follow up by asking question “b”.

**b. Are you a resident of the City of Fort Myers and/or Lee County**

- YES
- NO

If the answer is “NO,” this person is not a Section 3-eligible resident.

Therefore, there is not a need to ask question “c”.

**c. In the last 12 months, was your household income (meaning the total for everyone in your family earning income) NOT GREATER THAN the amount listed based on your household size?**

- YES
- NO

**If yes, have the employee complete the certification form (Exhibit 1) and attach this to your submission.**

3. For employees HIRED through HACFM, check the “hired through HACFM” box next to their name.



*City of Palms*

THE HOUSING AUTHORITY  
OF THE CITY OF FORT MYERS, FLORIDA

Page 2 of 4

### **SECTION 3 NEW HIRE COMPLIANCE REPORT**

4. Indicate whether each new hire is Section 3 eligible by checking the appropriate box next to their name and address on Section 3 New Hire Report. Indicate “Y” for Yes and “N” for No

5. Indicate the Job Category using the following codes:

Professionals	P
Technicians	T
Office and Clerical	OC
Sales	S
Trades	T
Labor	L
Service Workers	SW
Other	Other

6. An authorized representative of the firm must certify the accuracy and completeness of the information provided by signing this form where indicated.

7. Developers and contractors – who have direct agreements with HACFM regarding a Section 3 covered project – are responsible for collecting the Section 3 New Hire Report from all applicable contractors and sub-contractors performing on a Section 3 covered project. By December 31 of each year that the project is under construction, completed forms must be submitted to HACFM Section 3 Compliance Officer. If a project finishes construction before the end of the year, Section 3 New Hire Compliance Reports must be submitted within 30 days of completion.

8. If there were NO new hires for the report period, please document by checking the box and providing an authorized signature for your company.



*City of Palms*  
 THE HOUSING AUTHORITY  
 OF THE CITY OF FORT MYERS, FLORIDA

## SECTION 3 NEW HIRE COMPLIANCE REPORT

	NAME OF NEW HIRE	ADDRESS (include Suite/Apt #)	Section 3 Eligible?		Labor Category
			YES OR NO	Provided by HACFM	See Instructions
1					
2					
3					
4					
5					
6					
7					
8					
9					
10					
11					
12					
13					

If there were NO new hires for the report period, please document by checking the box and providing an authorized signature for your company.

- I certify that there were no new hires during the reporting period \_\_\_ / \_\_\_ / \_\_\_  
 to \_\_\_ / \_\_\_ / \_\_\_ mm / dd / yyyy

**Name:** \_\_\_\_\_  
 (please print)

**Date:** \_\_\_\_\_

**Title:** \_\_\_\_\_  
 (please print)

**Signature:** \_\_\_\_\_

I affirm that the above statements are true, complete, and correct to the best of my knowledge and belief



*City of Palms*  
THE HOUSING AUTHORITY  
OF THE CITY OF FORT MYERS, FLORIDA

### **SECTION 3 NEW HIRE COMPLIANCE REPORT**

**Project Name:** \_\_\_\_\_

**Project Address:** \_\_\_\_\_

**Developer Name (if applicable):** \_\_\_\_\_

**General Contractor Name:** \_\_\_\_\_

**Name of Firm Completing This Form:** \_\_\_\_\_

**This Firm is a (check one):**

- Developer
  
- General Contractor  
Contract Amount: \$ \_\_\_\_\_
  
- Subcontractor  
Contract Amount: \$ \_\_\_\_\_
  
- Professional Services Consultant  
Contract Amount: \$ \_\_\_\_\_

**Contracts and subcontracts made with vendors to solely provide supplies and/or materials are not subject to the HUD Section 3 requirements. However, where such vendors also install such supplies and materials, said contracts and subcontracts above \$100,000 shall be subject to the HUD Section 3 requirements.**

"REGISTER OF WAGE DETERMINATIONS UNDER THE SERVICE CONTRACT ACT By direction of the Secretary of Labor	U.S. DEPARTMENT OF LABOR EMPLOYMENT STANDARDS ADMINISTRATION WAGE AND HOUR DIVISION WASHINGTON D.C. 20210  Wage Determination No.: 2015-4529 Revision No.: 17 Date Of Last Revision: 03/15/2022
Daniel W. Simms Director	Division of Wage Determinations

Note: Contracts subject to the Service Contract Act are generally required to pay at least the applicable minimum wage rate required under Executive Order 14026 or Executive Order 13658.

If the contract is entered into on or after January 30 2022 or the contract is renewed or extended (e.g. an option is exercised) on or after January 30 2022:	With certain exceptions Executive Order 14026 applies to the contract. The contractor must pay all covered workers at least \$15.00 per hour (or the applicable wage rate listed on this wage determination if it is higher) for all hours spent performing on the contract in 2022.
If the contract was awarded on or between January 1 2015 and January 29 2022 and the contract is not renewed or extended on or after January 30 2022:	With certain exceptions Executive Order 13658 applies to the contract. The contractor must pay all covered workers at least \$11.25 per hour (or the applicable wage rate listed on this wage determination if it is higher) for all hours spent performing on the contract in 2022.

The applicable Executive Order minimum wage rate will be adjusted annually. Additional information on contractor requirements and worker protections under the Executive Orders is available at <https://www.dol.gov/agencies/whd/government-contracts>.

State: Florida

Area: Florida County of Lee

**\*\*Fringe Benefits Required Follow the Occupational Listing\*\***

OCCUPATION CODE - TITLE	FOOTNOTE	RATE
01000 - Administrative Support And Clerical Occupations		
01011 - Accounting Clerk I		15.41
01012 - Accounting Clerk II		17.30
01013 - Accounting Clerk III		19.35
01020 - Administrative Assistant		25.24
01035 - Court Reporter		20.20
01041 - Customer Service Representative I		12.81***
01042 - Customer Service Representative II		13.99***
01043 - Customer Service Representative III		15.70
01051 - Data Entry Operator I		13.16***
01052 - Data Entry Operator II		14.36***
01060 - Dispatcher Motor Vehicle		17.73
01070 - Document Preparation Clerk		16.34
01090 - Duplicating Machine Operator		16.34
01111 - General Clerk I		13.15***
01112 - General Clerk II		14.35***
01113 - General Clerk III		16.11



01120 - Housing Referral Assistant	19.88
01141 - Messenger Courier	17.30
01191 - Order Clerk I	13.28***
01192 - Order Clerk II	14.49***
01261 - Personnel Assistant (Employment) I	16.14
01262 - Personnel Assistant (Employment) II	18.22
01263 - Personnel Assistant (Employment) III	20.12
01270 - Production Control Clerk	21.14
01290 - Rental Clerk	14.90***
01300 - Scheduler Maintenance	15.95
01311 - Secretary I	15.95
01312 - Secretary II	17.84
01313 - Secretary III	19.88
01320 - Service Order Dispatcher	15.85
01410 - Supply Technician	25.24
01420 - Survey Worker	17.01
01460 - Switchboard Operator/Receptionist	14.69***
01531 - Travel Clerk I	15.91
01532 - Travel Clerk II	17.21
01533 - Travel Clerk III	18.73
01611 - Word Processor I	15.02
01612 - Word Processor II	16.87
01613 - Word Processor III	18.87
05000 - Automotive Service Occupations	
05005 - Automobile Body Repairer Fiberglass	21.10
05010 - Automotive Electrician	20.79
05040 - Automotive Glass Installer	19.87
05070 - Automotive Worker	19.87
05110 - Mobile Equipment Servicer	18.02
05130 - Motor Equipment Metal Mechanic	21.75
05160 - Motor Equipment Metal Worker	19.87
05190 - Motor Vehicle Mechanic	20.88
05220 - Motor Vehicle Mechanic Helper	17.00
05250 - Motor Vehicle Upholstery Worker	18.94
05280 - Motor Vehicle Wrecker	19.87
05310 - Painter Automotive	20.79
05340 - Radiator Repair Specialist	19.87
05370 - Tire Repairer	14.96***
05400 - Transmission Repair Specialist	21.53
07000 - Food Preparation And Service Occupations	
07010 - Baker	16.44
07041 - Cook I	14.03***
07042 - Cook II	16.32
07070 - Dishwasher	11.79***
07130 - Food Service Worker	12.51***
07210 - Meat Cutter	18.67
07260 - Waiter/Waitress	10.17***
09000 - Furniture Maintenance And Repair Occupations	
09010 - Electrostatic Spray Painter	19.61
09040 - Furniture Handler	12.57***
09080 - Furniture Refinisher	19.24
09090 - Furniture Refinisher Helper	14.58***
09110 - Furniture Repairer Minor	16.84
09130 - Upholsterer	19.61
11000 - General Services And Support Occupations	
11030 - Cleaner Vehicles	11.76***
11060 - Elevator Operator	11.76***
11090 - Gardener	19.01
11122 - Housekeeping Aide	13.60***
11150 - Janitor	13.60***
11210 - Laborer Grounds Maintenance	14.37***
11240 - Maid or Houseman	11.23***
11260 - Pruner	12.64***
11270 - Tractor Operator	17.47
11330 - Trail Maintenance Worker	14.37***

11360 - Window Cleaner	15.46
12000 - Health Occupations	
12010 - Ambulance Driver	19.45
12011 - Breath Alcohol Technician	19.45
12012 - Certified Occupational Therapist Assistant	33.50
12015 - Certified Physical Therapist Assistant	31.17
12020 - Dental Assistant	20.25
12025 - Dental Hygienist	36.67
12030 - EKG Technician	21.37
12035 - Electroneurodiagnostic Technologist	21.37
12040 - Emergency Medical Technician	19.45
12071 - Licensed Practical Nurse I	17.44
12072 - Licensed Practical Nurse II	19.51
12073 - Licensed Practical Nurse III	21.75
12100 - Medical Assistant	17.16
12130 - Medical Laboratory Technician	26.53
12160 - Medical Record Clerk	17.07
12190 - Medical Record Technician	19.27
12195 - Medical Transcriptionist	18.29
12210 - Nuclear Medicine Technologist	37.44
12221 - Nursing Assistant I	11.61***
12222 - Nursing Assistant II	13.05***
12223 - Nursing Assistant III	14.23***
12224 - Nursing Assistant IV	15.98
12235 - Optical Dispenser	25.53
12236 - Optical Technician	17.39
12250 - Pharmacy Technician	16.31
12280 - Phlebotomist	15.24
12305 - Radiologic Technologist	29.97
12311 - Registered Nurse I	23.88
12312 - Registered Nurse II	28.73
12313 - Registered Nurse II Specialist	28.73
12314 - Registered Nurse III	34.77
12315 - Registered Nurse III Anesthetist	34.77
12316 - Registered Nurse IV	41.67
12317 - Scheduler (Drug and Alcohol Testing)	24.10
12320 - Substance Abuse Treatment Counselor	28.34
13000 - Information And Arts Occupations	
13011 - Exhibits Specialist I	23.08
13012 - Exhibits Specialist II	28.59
13013 - Exhibits Specialist III	34.97
13041 - Illustrator I	23.08
13042 - Illustrator II	28.59
13043 - Illustrator III	34.97
13047 - Librarian	31.66
13050 - Library Aide/Clerk	13.27***
13054 - Library Information Technology Systems Administrator	28.59
13058 - Library Technician	19.82
13061 - Media Specialist I	20.64
13062 - Media Specialist II	23.08
13063 - Media Specialist III	25.72
13071 - Photographer I	18.09
13072 - Photographer II	20.23
13073 - Photographer III	25.08
13074 - Photographer IV	29.18
13075 - Photographer V	35.30
13090 - Technical Order Library Clerk	17.60
13110 - Video Teleconference Technician	18.31
14000 - Information Technology Occupations	
14041 - Computer Operator I	17.33
14042 - Computer Operator II	19.37
14043 - Computer Operator III	21.59
14044 - Computer Operator IV	24.00
14045 - Computer Operator V	26.58

14071 - Computer Programmer I	(see 1)	22.92
14072 - Computer Programmer II	(see 1)	27.56
14073 - Computer Programmer III	(see 1)	
14074 - Computer Programmer IV	(see 1)	
14101 - Computer Systems Analyst I	(see 1)	
14102 - Computer Systems Analyst II	(see 1)	
14103 - Computer Systems Analyst III	(see 1)	
14150 - Peripheral Equipment Operator		17.33
14160 - Personal Computer Support Technician		24.00
14170 - System Support Specialist		27.71
15000 - Instructional Occupations		
15010 - Aircrew Training Devices Instructor (Non-Rated)		29.13
15020 - Aircrew Training Devices Instructor (Rated)		35.25
15030 - Air Crew Training Devices Instructor (Pilot)		42.24
15050 - Computer Based Training Specialist / Instructor		29.13
15060 - Educational Technologist		29.79
15070 - Flight Instructor (Pilot)		42.24
15080 - Graphic Artist		22.03
15085 - Maintenance Test Pilot Fixed Jet/Prop		42.24
15086 - Maintenance Test Pilot Rotary Wing		42.24
15088 - Non-Maintenance Test/Co-Pilot		42.24
15090 - Technical Instructor		22.94
15095 - Technical Instructor/Course Developer		28.06
15110 - Test Proctor		18.52
15120 - Tutor		18.52
16000 - Laundry Dry-Cleaning Pressing And Related Occupations		
16010 - Assembler		10.49***
16030 - Counter Attendant		10.49***
16040 - Dry Cleaner		13.31***
16070 - Finisher Flatwork Machine		10.49***
16090 - Presser Hand		10.49***
16110 - Presser Machine Drycleaning		10.49***
16130 - Presser Machine Shirts		10.49***
16160 - Presser Machine Wearing Apparel Laundry		10.49***
16190 - Sewing Machine Operator		14.24***
16220 - Tailor		15.13
16250 - Washer Machine		11.48***
19000 - Machine Tool Operation And Repair Occupations		
19010 - Machine-Tool Operator (Tool Room)		22.18
19040 - Tool And Die Maker		27.01
21000 - Materials Handling And Packing Occupations		
21020 - Forklift Operator		20.35
21030 - Material Coordinator		19.82
21040 - Material Expediter		19.82
21050 - Material Handling Laborer		13.81***
21071 - Order Filler		13.49***
21080 - Production Line Worker (Food Processing)		20.35
21110 - Shipping Packer		14.54***
21130 - Shipping/Receiving Clerk		14.54***
21140 - Store Worker I		11.33***
21150 - Stock Clerk		16.18
21210 - Tools And Parts Attendant		20.35
21410 - Warehouse Specialist		20.35
23000 - Mechanics And Maintenance And Repair Occupations		
23010 - Aerospace Structural Welder		29.49
23019 - Aircraft Logs and Records Technician		23.98
23021 - Aircraft Mechanic I		28.01
23022 - Aircraft Mechanic II		29.49
23023 - Aircraft Mechanic III		30.76
23040 - Aircraft Mechanic Helper		21.54
23050 - Aircraft Painter		25.62
23060 - Aircraft Servicer		23.98
23070 - Aircraft Survival Flight Equipment Technician		25.62
23080 - Aircraft Worker		25.16
23091 - Aircrew Life Support Equipment (ALSE) Mechanic		25.16

I	
23092 - Aircrew Life Support Equipment (ALSE) Mechanic	28.01
II	
23110 - Appliance Mechanic	21.43
23120 - Bicycle Repairer	18.14
23125 - Cable Splicer	28.08
23130 - Carpenter Maintenance	19.56
23140 - Carpet Layer	20.19
23160 - Electrician Maintenance	21.81
23181 - Electronics Technician Maintenance I	23.81
23182 - Electronics Technician Maintenance II	25.31
23183 - Electronics Technician Maintenance III	26.93
23260 - Fabric Worker	19.63
23290 - Fire Alarm System Mechanic	23.14
23310 - Fire Extinguisher Repairer	18.14
23311 - Fuel Distribution System Mechanic	22.80
23312 - Fuel Distribution System Operator	17.33
23370 - General Maintenance Worker	18.50
23380 - Ground Support Equipment Mechanic	28.01
23381 - Ground Support Equipment Servicer	23.98
23382 - Ground Support Equipment Worker	25.16
23391 - Gunsmith I	18.14
23392 - Gunsmith II	21.09
23393 - Gunsmith III	23.86
23410 - Heating Ventilation And Air-Conditioning Mechanic	23.39
23411 - Heating Ventilation And Air Contidioning Mechanic (Research Facility)	24.64
23430 - Heavy Equipment Mechanic	24.81
23440 - Heavy Equipment Operator	19.10
23460 - Instrument Mechanic	23.86
23465 - Laboratory/Shelter Mechanic	22.42
23470 - Laborer	13.85***
23510 - Locksmith	22.35
23530 - Machinery Maintenance Mechanic	25.28
23550 - Machinist Maintenance	20.99
23580 - Maintenance Trades Helper	15.68
23591 - Metrology Technician I	23.86
23592 - Metrology Technician II	25.13
23593 - Metrology Technician III	26.20
23640 - Millwright	23.86
23710 - Office Appliance Repairer	19.42
23760 - Painter Maintenance	17.67
23790 - Pipefitter Maintenance	23.43
23810 - Plumber Maintenance	22.02
23820 - Pneudraulic Systems Mechanic	23.86
23850 - Rigger	23.86
23870 - Scale Mechanic	21.09
23890 - Sheet-Metal Worker Maintenance	19.44
23910 - Small Engine Mechanic	17.97
23931 - Telecommunications Mechanic I	26.66
23932 - Telecommunications Mechanic II	28.09
23950 - Telephone Lineman	25.74
23960 - Welder Combination Maintenance	20.49
23965 - Well Driller	22.82
23970 - Woodcraft Worker	23.86
23980 - Woodworker	18.14
24000 - Personal Needs Occupations	
24550 - Case Manager	20.08
24570 - Child Care Attendant	12.25***
24580 - Child Care Center Clerk	15.51
24610 - Chore Aide	12.01***
24620 - Family Readiness And Support Services Coordinator	20.08
24630 - Homemaker	20.08

25000 - Plant And System Operations Occupations	
25010 - Boiler Tender	23.86
25040 - Sewage Plant Operator	23.49
25070 - Stationary Engineer	23.86
25190 - Ventilation Equipment Tender	16.67
25210 - Water Treatment Plant Operator	23.49
27000 - Protective Service Occupations	
27004 - Alarm Monitor	18.16
27007 - Baggage Inspector	13.04***
27008 - Corrections Officer	27.11
27010 - Court Security Officer	27.11
27030 - Detection Dog Handler	16.69
27040 - Detention Officer	27.11
27070 - Firefighter	27.11
27101 - Guard I	13.04***
27102 - Guard II	16.69
27131 - Police Officer I	24.05
27132 - Police Officer II	26.80
28000 - Recreation Occupations	
28041 - Carnival Equipment Operator	15.70
28042 - Carnival Equipment Repairer	17.08
28043 - Carnival Worker	11.36***
28210 - Gate Attendant/Gate Tender	16.55
28310 - Lifeguard	14.17***
28350 - Park Attendant (Aide)	18.50
28510 - Recreation Aide/Health Facility Attendant	13.50***
28515 - Recreation Specialist	22.92
28630 - Sports Official	14.73***
28690 - Swimming Pool Operator	19.87
29000 - Stevedoring/Longshoremen Occupational Services	
29010 - Blocker And Bracer	27.79
29020 - Hatch Tender	27.79
29030 - Line Handler	27.79
29041 - Stevedore I	25.87
29042 - Stevedore II	29.54
30000 - Technical Occupations	
30010 - Air Traffic Control Specialist Center (HFO) (see 2)	40.29
30011 - Air Traffic Control Specialist Station (HFO) (see 2)	27.78
30012 - Air Traffic Control Specialist Terminal (HFO) (see 2)	30.59
30021 - Archeological Technician I	18.15
30022 - Archeological Technician II	20.32
30023 - Archeological Technician III	25.16
30030 - Cartographic Technician	25.16
30040 - Civil Engineering Technician	29.28
30051 - Cryogenic Technician I	27.87
30052 - Cryogenic Technician II	30.78
30061 - Drafter/CAD Operator I	18.15
30062 - Drafter/CAD Operator II	20.32
30063 - Drafter/CAD Operator III	22.65
30064 - Drafter/CAD Operator IV	27.87
30081 - Engineering Technician I	16.69
30082 - Engineering Technician II	18.74
30083 - Engineering Technician III	21.23
30084 - Engineering Technician IV	25.16
30085 - Engineering Technician V	30.78
30086 - Engineering Technician VI	37.25
30090 - Environmental Technician	25.16
30095 - Evidence Control Specialist	25.16
30210 - Laboratory Technician	22.65
30221 - Latent Fingerprint Technician I	24.81
30222 - Latent Fingerprint Technician II	27.39
30240 - Mathematical Technician	25.16
30361 - Paralegal/Legal Assistant I	20.51
30362 - Paralegal/Legal Assistant II	25.41
30363 - Paralegal/Legal Assistant III	31.08

30364 - Paralegal/Legal Assistant IV	37.62
30375 - Petroleum Supply Specialist	30.78
30390 - Photo-Optics Technician	25.16
30395 - Radiation Control Technician	30.78
30461 - Technical Writer I	24.10
30462 - Technical Writer II	29.47
30463 - Technical Writer III	35.66
30491 - Unexploded Ordnance (UXO) Technician I	25.60
30492 - Unexploded Ordnance (UXO) Technician II	30.98
30493 - Unexploded Ordnance (UXO) Technician III	37.13
30494 - Unexploded (UXO) Safety Escort	25.60
30495 - Unexploded (UXO) Sweep Personnel	25.60
30501 - Weather Forecaster I	27.87
30502 - Weather Forecaster II	33.91
30620 - Weather Observer Combined Upper Air Or	(see 2) 22.65
Surface Programs	
30621 - Weather Observer Senior	(see 2) 25.16
31000 - Transportation/Mobile Equipment Operation Occupations	
31010 - Airplane Pilot	30.98
31020 - Bus Aide	12.61***
31030 - Bus Driver	18.05
31043 - Driver Courier	15.30
31260 - Parking and Lot Attendant	10.78***
31290 - Shuttle Bus Driver	16.40
31310 - Taxi Driver	13.34***
31361 - Truckdriver Light	16.65
31362 - Truckdriver Medium	18.03
31363 - Truckdriver Heavy	19.54
31364 - Truckdriver Tractor-Trailer	19.54
99000 - Miscellaneous Occupations	
99020 - Cabin Safety Specialist	15.10
99030 - Cashier	11.63***
99050 - Desk Clerk	12.81***
99095 - Embalmer	26.58
99130 - Flight Follower	25.60
99251 - Laboratory Animal Caretaker I	13.33***
99252 - Laboratory Animal Caretaker II	14.50***
99260 - Marketing Analyst	27.98
99310 - Mortician	26.58
99410 - Pest Controller	16.86
99510 - Photofinishing Worker	14.66***
99710 - Recycling Laborer	19.69
99711 - Recycling Specialist	23.94
99730 - Refuse Collector	17.31
99810 - Sales Clerk	12.49***
99820 - School Crossing Guard	12.84***
99830 - Survey Party Chief	19.48
99831 - Surveying Aide	11.98***
99832 - Surveying Technician	18.29
99840 - Vending Machine Attendant	14.83***
99841 - Vending Machine Repairer	18.67
99842 - Vending Machine Repairer Helper	14.83***

\*\*\*Workers in this classification may be entitled to a higher minimum wage under Executive Order 14026 (\$15.00 per hour) or 13658 (\$11.25 per hour). Please see the Note at the top of the wage determination for more information. Please also note that the minimum wage requirements of Executive Order 14026 and 13658 are not currently being enforced as to contracts or contract-like instruments entered into with the federal government in connection with seasonal recreational services or seasonal recreational equipment rental for the general public on federal lands.

Note: Executive Order (EO) 13706 Establishing Paid Sick Leave for Federal Contractors applies to all contracts subject to the Service Contract Act for which the contract is awarded (and any solicitation was issued) on or after January 1 2017. If this contract is covered by the EO the contractor must provide employees with 1 hour of paid sick leave for every 30 hours they work up to 56 hours of paid sick leave each year. Employees must be permitted to use paid sick leave for their own illness injury or other health-related needs including preventive care; to assist a family member (or person who is like family to the employee) who is ill injured or has other health-related needs including preventive care; or for reasons resulting from or to assist a family member (or person who is like family to the employee) who is the victim of domestic violence sexual assault or stalking. Additional information on contractor requirements and worker protections under the EO is available at [www.dol.gov/whd/govcontracts](http://www.dol.gov/whd/govcontracts).

ALL OCCUPATIONS LISTED ABOVE RECEIVE THE FOLLOWING BENEFITS:

HEALTH & WELFARE: \$4.60 per hour up to 40 hours per week or \$184.00 per week or \$797.33 per month

HEALTH & WELFARE EO 13706: \$4.23 per hour up to 40 hours per week or \$169.20 per week or \$733.20 per month\*

\*This rate is to be used only when compensating employees for performance on an SCA-covered contract also covered by EO 13706 Establishing Paid Sick Leave for Federal Contractors. A contractor may not receive credit toward its SCA obligations for any paid sick leave provided pursuant to EO 13706.

VACATION: 2 weeks paid vacation after 1 year of service with a contractor or successor; and 3 weeks after 5 years. Length of service includes the whole span of continuous service with the present contractor or successor wherever employed and with the predecessor contractors in the performance of similar work at the same Federal facility. (Reg. 29 CFR 4.173)

HOLIDAYS: A minimum of eleven paid holidays per year: New Year's Day Martin Luther King Jr.'s Birthday Washington's Birthday Memorial Day Juneteenth National Independence Day Independence Day Labor Day Columbus Day Veterans' Day Thanksgiving Day and Christmas Day. (A contractor may substitute for any of the named holidays another day off with pay in accordance with a plan communicated to the employees involved.) (See 29 CFR 4.174)

THE OCCUPATIONS WHICH HAVE NUMBERED FOOTNOTES IN PARENTHESES RECEIVE THE FOLLOWING:

1) COMPUTER EMPLOYEES: Under the SCA at section 8(b) this wage determination does not apply to any employee who individually qualifies as a bona fide executive administrative or professional employee as defined in 29 C.F.R. Part 541. Because most Computer System Analysts and Computer Programmers who are compensated at a rate not less than \$27.63 (or on a salary or fee basis at a rate not less than \$455 per week) an hour would likely qualify as exempt computer professionals (29 C.F.R. 541.400) wage rates may not be listed on this wage determination for all occupations within those job families. In addition because this wage determination may not list a wage rate for some or all occupations within those job families if the survey data indicates that the prevailing wage rate for the occupation equals or exceeds \$27.63 per hour conformances may be necessary for certain nonexempt employees. For example if an individual employee is nonexempt but nevertheless performs duties within the scope of one of the Computer Systems Analyst or Computer Programmer occupations for which this wage determination does not specify an SCA wage rate then the wage rate for that employee must be conformed in accordance with the conformance procedures described in the conformance note included on this wage determination.

Additionally because job titles vary widely and change quickly in the computer industry job titles are not determinative of the application of the computer professional exemption. Therefore the exemption applies only to computer employees

who satisfy the compensation requirements and whose primary duty consists of:

(1) The application of systems analysis techniques and procedures including consulting with users to determine hardware software or system functional specifications;

(2) The design development documentation analysis creation testing or modification of computer systems or programs including prototypes based on and related to user or system design specifications;

(3) The design documentation testing creation or modification of computer programs related to machine operating systems; or

(4) A combination of the aforementioned duties the performance of which requires the same level of skills. (29 C.F.R. 541.400).

2) AIR TRAFFIC CONTROLLERS AND WEATHER OBSERVERS - NIGHT PAY & SUNDAY PAY: If you work at night as part of a regular tour of duty you will earn a night differential and receive an additional 10% of basic pay for any hours worked between 6pm and 6am. If you are a full-time employed (40 hours a week) and Sunday is part of your regularly scheduled workweek you are paid at your rate of basic pay plus a Sunday premium of 25% of your basic rate for each hour of Sunday work which is not overtime (i.e. occasional work on Sunday outside the normal tour of duty is considered overtime work).

**\*\* HAZARDOUS PAY DIFFERENTIAL \*\***

An 8 percent differential is applicable to employees employed in a position that represents a high degree of hazard when working with or in close proximity to ordnance explosives and incendiary materials. This includes work such as screening blending dying mixing and pressing of sensitive ordnance explosives and pyrotechnic compositions such as lead azide black powder and photoflash powder. All dry-house activities involving propellants or explosives. Demilitarization modification renovation demolition and maintenance operations on sensitive ordnance explosives and incendiary materials. All operations involving re-grading and cleaning of artillery ranges.

A 4 percent differential is applicable to employees employed in a position that represents a low degree of hazard when working with or in close proximity to ordnance (or employees possibly adjacent to) explosives and incendiary materials which involves potential injury such as laceration of hands face or arms of the employee engaged in the operation irritation of the skin minor burns and the like; minimal damage to immediate or adjacent work area or equipment being used. All operations involving unloading storage and hauling of ordnance explosive and incendiary ordnance material other than small arms ammunition. These differentials are only applicable to work that has been specifically designated by the agency for ordnance explosives and incendiary material differential pay.

**\*\* UNIFORM ALLOWANCE \*\***

If employees are required to wear uniforms in the performance of this contract (either by the terms of the Government contract by the employer by the state or local law etc.) the cost of furnishing such uniforms and maintaining (by laundering or dry cleaning) such uniforms is an expense that may not be borne by an employee where such cost reduces the hourly rate below that required by the wage determination. The Department of Labor will accept payment in accordance with the following standards as compliance:

The contractor or subcontractor is required to furnish all employees with an adequate number of uniforms without cost or to reimburse employees for the actual cost of the uniforms. In addition where uniform cleaning and maintenance is made the responsibility of the employee all contractors and subcontractors subject to this wage determination shall (in the absence of a bona fide collective bargaining agreement providing for a different amount or the furnishing of contrary



affirmative proof as to the actual cost) reimburse all employees for such cleaning and maintenance at a rate of \$3.35 per week (or \$.67 cents per day). However in those instances where the uniforms furnished are made of "wash and wear" materials may be routinely washed and dried with other personal garments and do not require any special treatment such as dry cleaning daily washing or commercial laundering in order to meet the cleanliness or appearance standards set by the terms of the Government contract by the contractor by law or by the nature of the work there is no requirement that employees be reimbursed for uniform maintenance costs.

**\*\* SERVICE CONTRACT ACT DIRECTORY OF OCCUPATIONS \*\***

The duties of employees under job titles listed are those described in the "Service Contract Act Directory of Occupations" Fifth Edition (Revision 1) dated September 2015 unless otherwise indicated.

**\*\* REQUEST FOR AUTHORIZATION OF ADDITIONAL CLASSIFICATION AND WAGE RATE Standard Form 1444 (SF-1444) \*\***

**Conformance Process:**

The contracting officer shall require that any class of service employee which is not listed herein and which is to be employed under the contract (i.e. the work to be performed is not performed by any classification listed in the wage determination) be classified by the contractor so as to provide a reasonable relationship (i.e. appropriate level of skill comparison) between such unlisted classifications and the classifications listed in the wage determination (See 29 CFR 4.6(b)(2)(i)). Such conforming procedures shall be initiated by the contractor prior to the performance of contract work by such unlisted class(es) of employees (See 29 CFR 4.6(b)(2)(ii)). The Wage and Hour Division shall make a final determination of conformed classification wage rate and/or fringe benefits which shall be paid to all employees performing in the classification from the first day of work on which contract work is performed by them in the classification. Failure to pay such unlisted employees the compensation agreed upon by the interested parties and/or fully determined by the Wage and Hour Division retroactive to the date such class of employees commenced contract work shall be a violation of the Act and this contract. (See 29 CFR 4.6(b)(2)(v)). When multiple wage determinations are included in a contract a separate SF-1444 should be prepared for each wage determination to which a class(es) is to be conformed.

The process for preparing a conformance request is as follows:

- 1) When preparing the bid the contractor identifies the need for a conformed occupation(s) and computes a proposed rate(s).
- 2) After contract award the contractor prepares a written report listing in order the proposed classification title(s) a Federal grade equivalency (FGE) for each proposed classification(s) job description(s) and rationale for proposed wage rate(s) including information regarding the agreement or disagreement of the authorized representative of the employees involved or where there is no authorized representative the employees themselves. This report should be submitted to the contracting officer no later than 30 days after such unlisted class(es) of employees performs any contract work.
- 3) The contracting officer reviews the proposed action and promptly submits a report of the action together with the agency's recommendations and pertinent information including the position of the contractor and the employees to the U.S. Department of Labor Wage and Hour Division for review (See 29 CFR 4.6(b)(2)(ii)).
- 4) Within 30 days of receipt the Wage and Hour Division approves modifies or disapproves the action via transmittal to the agency contracting officer or notifies the contracting officer that additional time will be required to process the request.
- 5) The contracting officer transmits the Wage and Hour Division's decision to the contractor.

6) Each affected employee shall be furnished by the contractor with a written copy of such determination or it shall be posted as a part of the wage determination (See 29 CFR 4.6(b)(2)(iii)).

Information required by the Regulations must be submitted on SF-1444 or bond paper.

When preparing a conformance request the ""Service Contract Act Directory of Occupations"" should be used to compare job definitions to ensure that duties requested are not performed by a classification already listed in the wage determination. Remember it is not the job title but the required tasks that determine whether a class is included in an established wage determination. Conformances may not be used to artificially split combine or subdivide classifications listed in the wage determination (See 29 CFR 4.152(c)(1))."

"General Decision Number: FL20220120 02/25/2022

Superseded General Decision Number: FL20210120

State: Florida

Construction Type: Heavy

County: Lee County in Florida.

HEAVY CONSTRUCTION PROJECTS (Including Sewer and Water Lines)

Note: Contracts subject to the Davis-Bacon Act are generally required to pay at least the applicable minimum wage rate required under Executive Order 14026 or Executive Order 13658. Please note that these Executive Orders apply to covered contracts entered into by the federal government that are subject to the Davis-Bacon Act itself, but do not apply to contracts subject only to the Davis-Bacon Related Acts, including those set forth at 29 CFR 5.1(a)(2)-(60).

<p>If the contract is entered into on or after January 30, 2022, or the contract is renewed or extended (e.g., an option is exercised) on or after January 30, 2022:</p>	<ul style="list-style-type: none"> <li>. Executive Order 14026 generally applies to the contract.</li> <li>. The contractor must pay all covered workers at least \$15.00 per hour (or the applicable wage rate listed on this wage determination, if it is higher) for all hours spent performing on the contract in 2022.</li> </ul>
<p>If the contract was awarded on or between January 1, 2015 and January 29, 2022, and the contract is not renewed or extended on or after January 30, 2022:</p>	<ul style="list-style-type: none"> <li>. Executive Order 13658 generally applies to the contract.</li> <li>. The contractor must pay all covered workers at least \$11.25 per hour (or the applicable wage rate listed on this wage determination, if it is higher) for all hours spent performing on that contract in 2022.</li> </ul>

The applicable Executive Order minimum wage rate will be adjusted annually. If this contract is covered by one of the Executive Orders and a classification considered necessary for performance of work on the contract does not appear on this wage determination, the contractor must still submit a conformance request.

Additional information on contractor requirements and worker protections under the Executive Orders is available at <https://www.dol.gov/agencies/whd/government-contracts>.

Modification Number	Publication Date
0	01/07/2022
1	02/25/2022

ELEC0915-003 12/01/2021

	Rates	Fringes
ELECTRICIAN.....	\$ 31.69	41%+\$0.35

-----  
ENGI0487-014 07/01/2013

	Rates	Fringes
OPERATOR: Crane All Tower Cranes Mobile, Rail, Climbers, Static- Mount; All Cranes with Boom Length 150 Feet & Over (With or without jib) Friction, Hydraulic, Electric or Otherwise; Cranes 150 Tons & Over; Cranes with 3 Drums (When 3rd drum is rigged for work); Gantry & Overhead Cranes; Hydraulic Cranes Over 25 Tons but not more than 50 Tons; Hydraulic/Friction Cranes; & All Types of Flying Cranes; Boom Truck.....	\$ 29.05	8.80
Cranes with Boom Length Less than 150 Feet (With or without jib); Hydraulic Cranes 25 Tons & Under, & Over 50 Tons (With Oiler); Boom Truck.....	\$ 28.32	8.80
OPERATOR: Drill.....	\$ 25.80	8.80
OPERATOR: Oiler.....	\$ 22.99	8.80

-----  
IRON0397-006 07/01/2021

	Rates	Fringes
IRONWORKER, STRUCTURAL.....	\$ 31.35	16.47

-----  
LAB01652-004 05/01/2018

	Rates	Fringes
LABORER: Grade Checker.....	\$ 22.05	7.27

-----  
PAIN0088-008 06/01/2021

	Rates	Fringes
PAINTER: Brush, Roller and Spray.....	\$ 20.21	12.38

\* SUFL2009-159 06/24/2009

	Rates	Fringes
CARPENTER.....	\$ 14.95 **	2.92
CEMENT MASON/CONCRETE FINISHER...	\$ 14.77 **	3.50
LABORER: Common or General.....	\$ 9.72 **	1.31

LABORER: Landscape.....	\$ 7.25 **	0.00
LABORER: Pipelayer.....	\$ 11.33 **	0.00
LABORER: Power Tool Operator (Hand Held Drills/Saws, Jackhammer and Power Saws Only).....	\$ 10.63 **	2.20
OPERATOR: Asphalt Paver.....	\$ 11.59 **	0.00
OPERATOR: Backhoe Loader Combo.....	\$ 16.10	2.44
OPERATOR: Backhoe/Excavator.....	\$ 14.91 **	1.08
OPERATOR: Bulldozer.....	\$ 17.00	0.00
OPERATOR: Grader/Blade.....	\$ 16.00	2.84
OPERATOR: Loader.....	\$ 14.75 **	0.00
OPERATOR: Mechanic.....	\$ 14.32 **	0.00
OPERATOR: Roller.....	\$ 10.76 **	0.00
OPERATOR: Scraper.....	\$ 11.00 **	1.74
OPERATOR: Trackhoe.....	\$ 20.92	5.50
OPERATOR: Tractor.....	\$ 10.54 **	0.00
TRUCK DRIVER, Includes Dump Truck.....	\$ 11.00 **	0.00
TRUCK DRIVER: Lowboy Truck.....	\$ 12.73 **	0.00
TRUCK DRIVER: Off the Road Truck.....	\$ 12.21 **	1.97

-----

WELDERS - Receive rate prescribed for craft performing operation to which welding is incidental.

=====  
 \*\* Workers in this classification may be entitled to a higher minimum wage under Executive Order 14026 (\$15.00) or 13658 (\$11.25). Please see the Note at the top of the wage determination for more information.

Note: Executive Order (EO) 13706, Establishing Paid Sick Leave for Federal Contractors applies to all contracts subject to the Davis-Bacon Act for which the contract is awarded (and any solicitation was issued) on or after January 1, 2017. If this contract is covered by the EO, the contractor must provide employees with 1 hour of paid sick leave for every 30 hours they work, up to 56 hours of paid sick leave each year. Employees must be permitted to use paid sick leave for their own illness, injury or other health-related needs, including preventive care; to assist a family member (or person who is like family to the employee) who is ill, injured, or has other health-related needs, including preventive care; or for reasons resulting from, or to assist a family member (or person who is

like family to the employee) who is a victim of, domestic violence, sexual assault, or stalking. Additional information on contractor requirements and worker protections under the EO is available at <https://www.dol.gov/agencies/whd/government-contracts>.

Unlisted classifications needed for work not included within the scope of the classifications listed may be added after award only as provided in the labor standards contract clauses (29CFR 5.5 (a) (1) (ii)).

-----

The body of each wage determination lists the classification and wage rates that have been found to be prevailing for the cited type(s) of construction in the area covered by the wage determination. The classifications are listed in alphabetical order of ""identifiers"" that indicate whether the particular rate is a union rate (current union negotiated rate for local), a survey rate (weighted average rate) or a union average rate (weighted union average rate).

#### Union Rate Identifiers

A four letter classification abbreviation identifier enclosed in dotted lines beginning with characters other than ""SU"" or ""UAVG"" denotes that the union classification and rate were prevailing for that classification in the survey. Example: PLUM0198-005 07/01/2014. PLUM is an abbreviation identifier of the union which prevailed in the survey for this classification, which in this example would be Plumbers. 0198 indicates the local union number or district council number where applicable, i.e., Plumbers Local 0198. The next number, 005 in the example, is an internal number used in processing the wage determination. 07/01/2014 is the effective date of the most current negotiated rate, which in this example is July 1, 2014.

Union prevailing wage rates are updated to reflect all rate changes in the collective bargaining agreement (CBA) governing this classification and rate.

#### Survey Rate Identifiers

Classifications listed under the ""SU"" identifier indicate that no one rate prevailed for this classification in the survey and the published rate is derived by computing a weighted average rate based on all the rates reported in the survey for that classification. As this weighted average rate includes all rates reported in the survey, it may include both union and non-union rates. Example: SULA2012-007 5/13/2014. SU indicates the rates are survey rates based on a weighted average calculation of rates and are not majority rates. LA indicates the State of Louisiana. 2012 is the year of survey on which these classifications and rates are based. The next number, 007 in the example, is an internal number used in producing the wage determination. 5/13/2014 indicates the survey completion date for the classifications and rates under that identifier.

Survey wage rates are not updated and remain in effect until a new survey is conducted.

#### Union Average Rate Identifiers

Classification(s) listed under the UAVG identifier indicate that no single majority rate prevailed for those classifications; however, 100% of the data reported for the classifications was union data. EXAMPLE: UAVG-OH-0010 08/29/2014. UAVG indicates that the rate is a weighted union average rate. OH indicates the state. The next number, 0010 in the example, is an internal number used in producing the wage determination. 08/29/2014 indicates the survey completion date for the classifications and rates under that identifier.

A UAVG rate will be updated once a year, usually in January of each year, to reflect a weighted average of the current negotiated/CBA rate of the union locals from which the rate is based.

-----

WAGE DETERMINATION APPEALS PROCESS

1.) Has there been an initial decision in the matter? This can be:

- \* an existing published wage determination
- \* a survey underlying a wage determination
- \* a Wage and Hour Division letter setting forth a position on a wage determination matter
- \* a conformance (additional classification and rate) ruling

On survey related matters, initial contact, including requests for summaries of surveys, should be with the Wage and Hour National Office because National Office has responsibility for the Davis-Bacon survey program. If the response from this initial contact is not satisfactory, then the process described in 2.) and 3.) should be followed.

With regard to any other matter not yet ripe for the formal process described here, initial contact should be with the Branch of Construction Wage Determinations. Write to:

Branch of Construction Wage Determinations  
Wage and Hour Division  
U.S. Department of Labor  
200 Constitution Avenue, N.W.  
Washington, DC 20210

2.) If the answer to the question in 1.) is yes, then an interested party (those affected by the action) can request review and reconsideration from the Wage and Hour Administrator (See 29 CFR Part 1.8 and 29 CFR Part 7). Write to:

Wage and Hour Administrator  
U.S. Department of Labor  
200 Constitution Avenue, N.W.  
Washington, DC 20210

The request should be accompanied by a full statement of the interested party's position and by any information (wage payment data, project description, area practice material, etc.) that the requestor considers relevant to the issue.

3.) If the decision of the Administrator is not favorable, an interested party may appeal directly to the Administrative

Review Board (formerly the Wage Appeals Board). Write to:

Administrative Review Board  
U.S. Department of Labor  
200 Constitution Avenue, N.W.  
Washington, DC 20210

4.) All decisions by the Administrative Review Board are final.

=====

END OF GENERAL DECISIO"



"General Decision Number: FL20220211 02/25/2022

Superseded General Decision Number: FL20210211

State: Florida

Construction Type: Building

County: Lee County in Florida.

BUILDING CONSTRUCTION PROJECTS (does not include single family homes or apartments up to and including 4 stories).

Note: Contracts subject to the Davis-Bacon Act are generally required to pay at least the applicable minimum wage rate required under Executive Order 14026 or Executive Order 13658. Please note that these Executive Orders apply to covered contracts entered into by the federal government that are subject to the Davis-Bacon Act itself, but do not apply to contracts subject only to the Davis-Bacon Related Acts, including those set forth at 29 CFR 5.1(a)(2)-(60).

<p>If the contract is entered into on or after January 30, 2022, or the contract is renewed or extended (e.g., an option is exercised) on or after January 30, 2022:</p>	<ul style="list-style-type: none"> <li>. Executive Order 14026 generally applies to the contract.</li> <li>. The contractor must pay all covered workers at least \$15.00 per hour (or the applicable wage rate listed on this wage determination, if it is higher) for all hours spent performing on the contract in 2022.</li> </ul>
<p>If the contract was awarded on or between January 1, 2015 and January 29, 2022, and the contract is not renewed or extended on or after January 30, 2022:</p>	<ul style="list-style-type: none"> <li>. Executive Order 13658 generally applies to the contract.</li> <li>. The contractor must pay all covered workers at least \$11.25 per hour (or the applicable wage rate listed on this wage determination, if it is higher) for all hours spent performing on that contract in 2022.</li> </ul>

The applicable Executive Order minimum wage rate will be adjusted annually. If this contract is covered by one of the Executive Orders and a classification considered necessary for performance of work on the contract does not appear on this wage determination, the contractor must still submit a conformance request.

Additional information on contractor requirements and worker protections under the Executive Orders is available at <https://www.dol.gov/agencies/whd/government-contracts>.

Modification Number	Publication Date
0	01/07/2022
1	02/18/2022

ASBE0067-003 01/01/2021

	Rates	Fringes
ASBESTOS WORKER/HEAT & FROST INSULATOR.....	\$ 30.12	13.11

ELEC0349-008 09/01/2021

	Rates	Fringes
ELECTRICIAN (Includes Low Voltage Wiring).....	\$ 32.05	11.56

ELEV0074-001 01/01/2022

	Rates	Fringes
ELEVATOR MECHANIC.....	\$ 45.56	36.885+a+b

FOOTNOTE:

A. Employer contributions 8% of regular hourly rate to vacation pay credit for employee who has worked in business more than 5 years; Employer contributions 6% of regular hourly rate to vacation pay credit for employee who has worked in business less than 5 years.

Paid Holidays: New Year's Day; Memorial Day; Independence Day; Labor Day; Thanksgiving Day; The Friday after Thanksgiving Day; and Christmas Day.

ENGI0487-021 07/01/2016

	Rates	Fringes
OPERATOR: Crane All Cranes 160 Ton Capacity and Over.....	\$ 33.05	9.20
All Cranes Over 15 Ton Capacity.....	\$ 32.05	9.20
OPERATOR: Forklift.....	\$ 23.25	9.20
OPERATOR: Mechanic.....	\$ 32.05	9.20
OPERATOR: Oiler.....	\$ 23.50	9.20

IRON0397-007 07/01/2021

	Rates	Fringes
IRONWORKER, STRUCTURAL.....	\$ 31.35	16.47

IRON0402-001 10/01/2021

	Rates	Fringes
IRONWORKER, ORNAMENTAL.....	\$ 25.50	14.66

\* SUFL2014-020 08/16/2016

	Rates	Fringes
CARPENTER.....	\$ 18.00	0.00

CEMENT MASON/CONCRETE FINISHER...\$ 14.85 **	0.60
IRONWORKER, REINFORCING.....\$ 26.37	12.65
LABORER: Common or General, Including Cement Mason Tending and Pipelaying.....\$ 14.41 **	0.00
OPERATOR: Backhoe/Excavator/Trackhoe.....\$ 22.07	8.80
OPERATOR: Bulldozer.....\$ 15.40	1.90
OPERATOR: Grader/Blade.....\$ 18.97	0.00
OPERATOR: Loader.....\$ 14.00 **	1.40
OPERATOR: Roller.....\$ 14.43 **	4.78
PAINTER: Brush, Roller and Spray.....\$ 14.72 **	2.13
PIPEFITTER.....\$ 21.36	7.93
PLUMBER.....\$ 18.01	2.88
ROOFER.....\$ 19.00	1.17
SHEET METAL WORKER, Includes HVAC Duct Installation.....\$ 20.11	3.41
SPRINKLER FITTER (Fire Sprinklers).....\$ 18.25	0.00
TILE SETTER.....\$ 18.01	0.00
TRUCK DRIVER: Dump Truck.....\$ 13.22 **	2.12
TRUCK DRIVER: Lowboy Truck.....\$ 14.24 **	0.00

-----

WELDERS - Receive rate prescribed for craft performing operation to which welding is incidental.

=====

\*\* Workers in this classification may be entitled to a higher minimum wage under Executive Order 14026 (\$15.00) or 13658 (\$11.25). Please see the Note at the top of the wage determination for more information.

Note: Executive Order (EO) 13706, Establishing Paid Sick Leave for Federal Contractors applies to all contracts subject to the Davis-Bacon Act for which the contract is awarded (and any solicitation was issued) on or after January 1, 2017. If this contract is covered by the EO, the contractor must provide employees with 1 hour of paid sick leave for every 30 hours they work, up to 56 hours of paid sick leave each year. Employees must be permitted to use paid sick leave for their own illness, injury or other health-related needs, including preventive care; to assist a family member (or person who is like family to the employee) who is ill, injured, or has other health-related needs, including preventive care; or for reasons resulting from, or to assist a family member (or person who is like family to the employee) who is a victim of, domestic

violence, sexual assault, or stalking. Additional information on contractor requirements and worker protections under the EO is available at <https://www.dol.gov/agencies/whd/government-contracts>.

Unlisted classifications needed for work not included within the scope of the classifications listed may be added after award only as provided in the labor standards contract clauses (29CFR 5.5 (a) (1) (ii)).

-----

The body of each wage determination lists the classification and wage rates that have been found to be prevailing for the cited type(s) of construction in the area covered by the wage determination. The classifications are listed in alphabetical order of "identifiers" that indicate whether the particular rate is a union rate (current union negotiated rate for local), a survey rate (weighted average rate) or a union average rate (weighted union average rate).

#### Union Rate Identifiers

A four letter classification abbreviation identifier enclosed in dotted lines beginning with characters other than "SU" or "UAVG" denotes that the union classification and rate were prevailing for that classification in the survey. Example: PLUM0198-005 07/01/2014. PLUM is an abbreviation identifier of the union which prevailed in the survey for this classification, which in this example would be Plumbers. 0198 indicates the local union number or district council number where applicable, i.e., Plumbers Local 0198. The next number, 005 in the example, is an internal number used in processing the wage determination. 07/01/2014 is the effective date of the most current negotiated rate, which in this example is July 1, 2014.

Union prevailing wage rates are updated to reflect all rate changes in the collective bargaining agreement (CBA) governing this classification and rate.

#### Survey Rate Identifiers

Classifications listed under the "SU" identifier indicate that no one rate prevailed for this classification in the survey and the published rate is derived by computing a weighted average rate based on all the rates reported in the survey for that classification. As this weighted average rate includes all rates reported in the survey, it may include both union and non-union rates. Example: SULA2012-007 5/13/2014. SU indicates the rates are survey rates based on a weighted average calculation of rates and are not majority rates. LA indicates the State of Louisiana. 2012 is the year of survey on which these classifications and rates are based. The next number, 007 in the example, is an internal number used in producing the wage determination. 5/13/2014 indicates the survey completion date for the classifications and rates under that identifier.

Survey wage rates are not updated and remain in effect until a new survey is conducted.

#### Union Average Rate Identifiers

Classification(s) listed under the UAVG identifier indicate that no single majority rate prevailed for those classifications; however, 100% of the data reported for the classifications was union data. EXAMPLE: UAVG-OH-0010 08/29/2014. UAVG indicates that the rate is a weighted union average rate. OH indicates the state. The next number, 0010 in the example, is an internal number used in producing the wage determination. 08/29/2014 indicates the survey completion date for the classifications and rates under that identifier.

A UAVG rate will be updated once a year, usually in January of each year, to reflect a weighted average of the current negotiated/CBA rate of the union locals from which the rate is based.

-----

#### WAGE DETERMINATION APPEALS PROCESS

1.) Has there been an initial decision in the matter? This can be:

- \* an existing published wage determination
- \* a survey underlying a wage determination
- \* a Wage and Hour Division letter setting forth a position on a wage determination matter
- \* a conformance (additional classification and rate) ruling

On survey related matters, initial contact, including requests for summaries of surveys, should be with the Wage and Hour National Office because National Office has responsibility for the Davis-Bacon survey program. If the response from this initial contact is not satisfactory, then the process described in 2.) and 3.) should be followed.

With regard to any other matter not yet ripe for the formal process described here, initial contact should be with the Branch of Construction Wage Determinations. Write to:

Branch of Construction Wage Determinations  
Wage and Hour Division  
U.S. Department of Labor  
200 Constitution Avenue, N.W.  
Washington, DC 20210

2.) If the answer to the question in 1.) is yes, then an interested party (those affected by the action) can request review and reconsideration from the Wage and Hour Administrator (See 29 CFR Part 1.8 and 29 CFR Part 7). Write to:

Wage and Hour Administrator  
U.S. Department of Labor  
200 Constitution Avenue, N.W.  
Washington, DC 20210

The request should be accompanied by a full statement of the interested party's position and by any information (wage payment data, project description, area practice material, etc.) that the requestor considers relevant to the issue.

3.) If the decision of the Administrator is not favorable, an interested party may appeal directly to the Administrative Review Board (formerly the Wage Appeals Board). Write to:

Administrative Review Board  
U.S. Department of Labor  
200 Constitution Avenue, N.W.  
Washington, DC 20210

4.) All decisions by the Administrative Review Board are final.

=====

END OF GENERAL DECISIO"



